



ILLUMINATION
STATION JOHN 8:12

VBS 2026

* KALEIDOSCOPE *

CRAFTS

3s—KINDERGARTEN

Crafts Rotation Leader Guide

ILLUMINATE!

SHINE A FLASHLIGHT

- Read the Scripture passage for each day. Ask your director for a copy of the “Leader Devotions” from the Administrative Guide printable files. Pray that God will speak to you through His Word. Teach from the overflow! Pray for the kids you will teach. Pray for yourself and the other leaders at VBS. Ask people to pray for you.

TURN ON THE LIGHT SWITCH

- Find out how long your teaching time will be and where you will teach. Will you be in a designated classroom or will you travel from room to room?
- Ask for an estimate of how many kids will be in your class.
- Determine the ages of the kids you will teach in each session.
- Know your church’s safety and security policies.

PLAN AHEAD FOR THE BEST EXPERIENCE

- Read through the teaching plans and highlight what you want to include.
- Meet with other leaders on your team to plan each daily session. Make a list of the supplies you will need.
- Try each craft before using it in a session. Choose those that are most appropriate for each group of preschoolers you will teach. You might consider choosing different crafts for different ages and abilities of kids.

TOOLS TO SHINE A LIGHT

- Ask if your church will purchase craft packs or if your team will be preparing the crafts.
- Copy the templates and coloring pages you plan to use (starting on page 30). Gather needed supplies. Some VBS directors will gather supplies for you. Others will ask that you gather your own. Find out how your church does this.
- Always plan for more kids than you think you’ll have so you’re not caught short on supplies.
- See pages 4–5 and 28–29 for more tips on gathering and preparing.

ACCESS YOUR REDEMPTION FILES ONLINE

- You can find the printable templates starting on page 30 of this book or by using the following instructions:
- Go to my.lifeway.com/redeem and register or log in.
- Enter this unique code to download all printable items:
RNLQXN4D7PTT
- Follow the directions to download your resources on any compatible device. See p. 30 for more details.
- For customer support, call 866.627.8553.

ENJOY GLITTER AND BE READY FOR SURPRISES!

- Be sure to connect each activity to the Bible story for the day.
- Relax and enjoy building relationships with your kids.
- In addition to a “free art” center, reserve a small space in your room for early finishers to sit with a book or play a quiet game with a leader while waiting for other kids to finish.
- Enlist extra hands for activities that may require more help from a leader.
- Be flexible. Adjust your plans to make this the best experience possible for you and your preschoolers.

KEEP ILLUMINATING

- Make sure your church has correct contact information for each kid in your group.
- Plan to take part in follow-up activities scheduled by your church.
- Look for ways to stay connected with the children.
- Consider teaching in your church’s preschool or children’s ministry on an ongoing basis during the year.



TABLE OF CONTENTS

ILLUMINATE!	1
TABLE OF CONTENTS	2
KALEIDOSCOPE CRAFTS	3
AT A GLANCE	4
SAFETY AND DECOR TIPS	6
DAY 1	7
• Pool Noodle Painting	
• Jesus Rocks	
• Dazzling Kaleidoscope	
• Craft Stick Lantern	
DAY 2	11
• Salt Painting	
• Baptism Scene	
• Tie-dye Suncatchers	
• Light Bulb Straw Painting	
DAY 3	15
• Fish Bible Marker	
• Basket of Food	
• Constellation Cube	
• String Painting	
DAY 4	19
• Surprise Message	
• Build a Scene	
• Laced Cross	
• Empty Tomb Silhouette	
DAY 5	23
• Craft Stick Puzzle	
• Glitter Art	
• Illumination Station Magnet	
• Scratch Art Picture Frame	
CRAFT PACK OPTIONS	27
SUPPLIES	28
TEMPLATES	30–35
COLORING PAGES	36–40

Publishing Team
Shelly Harris
Publishing Team Leader

Bethany Phillips
Content Editor

Rachel Woodruff
Production Editor

Keith Tyrrell
Graphic Designer

Jeremy Carroll
*Publishing Manager, VBS, Hyfi,
 and Kids Discipleship*

Chuck Peters
Director, NextGen Ministries

Donna Blaydes
Writer

Send questions or comments to:
 VBS Publishing Team Leader by email to
 vbs@lifeway.com
 or by mail to
 VBS Publishing Team Leader
Preschool Crafts Rotation Guide
 200 Powell Place, Suite 100
 Brentwood, TN 37027-7707
 or make comments on the web at lifeway.com.
 Printed in the United States of America
 © 2025 Lifeway Press®

No part of this work may be reproduced or transmitted
 in any form or by any means, electronic or mechanical,
 including photocopying and recording, or by any
 information storage or retrieval system, except as may
 be expressly permitted in writing by the publisher.
 Requests for permission should be
 addressed in writing to:

Lifeway Press
 200 Powell Place, Suite 100
 Brentwood, TN 37027-7707

ISBN: 9798384537502
 Item: 005853485

We believe that the Bible has God for its author;
 salvation for its end; and truth, without any mixture of
 error, for its matter; and that all Scripture is totally true
 and trustworthy. To review Lifeway's doctrinal guideline,
 please visit lifeway.com/doctrinalguideline.

Unless otherwise indicated, all Scripture quotations are
 taken from the Christian Standard Bible®, Copyright ©
 2017 by Holman Bible Publishers. Used by permission.
 Christian Standard Bible® and CSB® are federally
 registered trademarks of Holman Bible Publishers.

Illumination Station™ and any other trademarks, service
 marks, logos, and graphics used herein are the
 trademarks or registered trademarks or service marks
 of Lifeway. Other trademarks, service marks, graphics,
 and logos used in connection with this product may
 be the trademarks of their respective owners. You are
 granted no right or license with respect to any of the
 trademarks or service marks mentioned above or any
 use of such trademarks or service marks except as
 specifically stated within this product.



KALEIDOSCOPE CRAFTS

Culture claims to know about Jesus, but many people are in the dark about who He really is. Some might see Jesus as just a person from history or a good man or a good teacher—but He is more than that! This summer, VBS will shine a light on the truth of who Jesus really is.

Meet us at Illumination Station for the brightest week of the year. Focus on Jesus at Spotlight Bible Study and bask in the colorful glow of sunlight streaming in at Suncatcher Recreation. Twirl in the glittering refracted light of Mirror Ball Music and pass through strands of twinkling lights on the way to Kaleidoscope Crafts. Turn it all the way up for Neon Snacks and bring it all the way down for Glow-in-the-dark Missions. Kids will explore all the ways light brightens, illuminates, reflects, and reveals while discovering that Jesus is the light who brings hope to a dark world! Like the disciples, kids will be challenged to answer Jesus' question, "Who do you say that I am?" They will discover it's not a matter of opinion. Jesus is who Scripture says He is—the perfect, proven, and powerful Son of God.

Light up your summer at Illumination Station and shine a light on Jesus!

Take some time now to look through the activities suggested for all five days. There is always at least one activity that relates specifically to the Bible story for each day. In addition, you'll see theme-oriented activities. Choose a couple of projects each day, based on what works best for your kids. No matter which crafts you choose, be sure to share the Bible story summary for each day.

A "free art" suggestion is provided each day and is designed to be relatively self-directed with minimal supervision. Use these options for early finishers or an easy additional activity as needed.

Coloring pages of the daily Bible Story Pictures are included at the back of this booklet. These pictures offer another free art project for your early finishers. Take a moment to talk with the kid about the picture as he colors. Remind him of the Bible story.

Remember ...

- Help kids know more about who Jesus is.
- Build relationships with the kids as they participate in these activities.
- The process is more important than the finished project.
- Enjoy playing!



AT A GLANCE

MOTTO

JESUS is
THE LIGHT
of THE WORLD

BIBLE VERSE

Jesus said, "I am the light
of the world."
John 8:12
(paraphrase)

The crafts in this guide are designed to reinforce the Bible story, biblical truths, and enhance the overall VBS experience.

All crafts are written for preschoolers ages 3 through completed kindergarten.

DAY 1

JESUS IS GOD'S PROMISED SON

JESUS ASKED WHO PEOPLE THOUGHT HE WAS

Matthew 16:13-20

Jesus asked His disciples (helpers) a question. "Who do people say I am?" Jesus asked. The disciples told Jesus that people had different ideas about who Jesus was. Jesus asked His disciples, "But who do you say that I am?" Peter, one of the disciples, answered, "You are God's Son." Jesus said Peter could only know this because God had helped Peter know. Jesus said that Peter would tell people about Jesus.

TODAY'S POINT

Jesus is God's promised Son.

TODAY'S CRAFTS

- Pool Noodle Painting
- Jesus Rocks
- Dazzling Kaleidoscope
- Craft Stick Lantern

DAY 2

JESUS IS GOD'S PERFECT SON

THE BAPTISM OF JESUS

*Matthew 3:13-17; Mark 1:1-11;
John 1:29-34*

God sent John the Baptist to get people ready for Jesus. Jesus told John that He wanted to be baptized because God said it was right so John baptized Jesus. God's voice came from heaven. "This is My Son," the voice said. "I love Him, and I am very pleased with Him!"

TODAY'S POINT

Jesus is God's perfect Son.

TODAY'S CRAFTS

- Salt Painting
- Baptism Scene
- Tie-dye Suncatchers
- Light Bulb Straw Painting

PREPARING FOR KALEIDOSCOPE CRAFTS

- Choose one or two activities for each day. Don't feel that you need to offer all four suggestions.
- Determine which supplies can be collected by church members, which ones are stocked in your resource room, and which items need to be purchased.
- Copy and prepare any of the needed templates located in the back of this guide. (Use the link provided on page 1 to download the templates digitally.)
- Label a box or bag for each day and place collected supplies in the appropriate box.



DAY 3
JESUS IS THE POWERFUL SON OF GOD

JESUS PERFORMED MIRACLES

Matthew 15:29-39

Large crowds came and Jesus healed sick people in the crowd. Jesus wanted to provide food. The disciples had 7 loaves of bread and a few small fish. Jesus thanked God for the food and broke it into pieces. There was enough for everyone to eat until they were full and there were 7 large baskets of leftovers! Jesus fed 4,000 men plus women and children that day.

TODAY'S POINT

Jesus is the powerful Son of God.

TODAY'S CRAFTS

- Fish Bible Marker
- Basket of Food
- Constellation Cube
- String Painting

DAY 4
JESUS IS THE PROVEN SON OF GOD

JESUS DIED AND ROSE TO LIFE

Mark 14:43-16:7

Jesus was arrested, put on trial, and nailed to a cross. After Jesus died, He was buried in a tomb. Some women went to the tomb. When they got there, they saw that the stone had been rolled away. They went in but did not find Jesus' body. Instead, a man dressed in a white robe told them Jesus is alive!

TODAY'S POINT

Jesus is alive!

TODAY'S CRAFTS

- Surprise Message
- Build a Scene
- Laced Cross
- Empty Tomb Silhouette

DAY 5
JESUS IS GOD'S PLAN FOR FORGIVENESS

PETER PREACHED ABOUT JESUS

Acts 2

Peter told a crowd that God had proven who Jesus was by doing things no one else could do. As the people listened to Peter, they were sad. They knew they had disobeyed God (sinned). The people were sorry they had disobeyed God. They wanted to do what God wanted them to do. That day, about 3,000 people decided to become followers of Jesus!

TODAY'S POINT

Jesus is God's plan for forgiveness.

TODAY'S CRAFTS

- Craft Stick Puzzle
- Glitter Art
- Illumination Station Magnet
- Scratch Art Picture Frame

TIPS TO TAKE THE STRESS OUT OF CRAFT PREP

- Ask adult and student small groups to sponsor an art activity. The group could cut out the needed materials, donate the supplies, or donate money to purchase craft packs.
- Ask a student group to package supplies in ziplock bags, one for each kid. As kids enter the room, give a bag to each kid with the supplies to make her craft. She can place the completed craft back in the bag to take home.
- Host a Crafts Prep Party a few weeks before VBS begins. Invite church members to come and help with the advance preparation. Include a light dinner or snacks.
- Use address labels to attach children's names or the week's Bible verse to their artwork.

SAFETY TIPS

- Locate rotation sites close to each other, such as next door or right across the hallway.
- Maintain appropriate leader/kid ratios, especially while traveling to and from rotations. Try to maintain a maximum of 16 kids per class for 3s–Pre-K and 20 kindergartners per class. One leader is suggested for every four kids for 3s–Pre-K and one for every five kindergartners.
- Always have a minimum of two leaders per classroom. Ask at least two leaders to accompany the group to Kaleidoscope Crafts. The leaders will be aware of any special needs of the kids and will provide a sense of security for the kids.
- Enlist a leader to lead the line and another leader to walk at the end of the line.
- Use a walking rope or the “buddy system” (friends holding hands, walking side by side) to keep kids together.
- Keep an accurate daily attendance list with you as you travel to make sure everyone is accounted for at all times.
- Post all rotation schedules in the VBS classrooms. This will help leaders assist parents in locating their kids during VBS.

DECOR TIPS

Sometimes less is more! Too many decorations can be distracting to some kids and can cause behavior problems. Remember that relationship-building is far more important than what the room looks like.

- Create a path of neon lights leading into your room using the *VBS 2026 Floor Prints* (9798384538219).
- Hang posters from the *VBS 2026 Visual Pack* (9798384538585) on the walls.
- Drape *VBS 2026 String Flags* (9798384538226) from the ceiling.
- Use *VBS 2026 Cups* (9798384538059) to store craft supplies.
- Protect tables with *VBS 2026 Tablecloths* (9798384538189).
- Attach the appropriate *VBS 2026 Rotation Sign* (9798384538615) outside the door.
- See *VBS 2026 Decorating Made Easy* (9798384536987) for additional ideas.



JESUS IS GOD'S PROMISED SON



Today's Point

Jesus is God's promised Son.

Jesus Asked Who People Thought He Was (Matthew 16:13-20)

Jesus asked His disciples (helpers) a question. "Who do people say I am?" Jesus asked. The disciples told Jesus that people had different ideas about who Jesus was. Jesus asked His disciples, "But who do you say that I am?" Peter, one of the disciples, answered, "You are God's Son." Jesus said Peter could only know this because God had helped Peter know. Jesus said that Peter would tell people about Jesus.

DAY 1

GATHER SUPPLIES

- Washable glow-in-the-dark paints
- Painting smocks
- Paper plates (1 per color)
- Pool noodles (different shapes, if available)
- Cardstock (white) (1 per kid)
- Marker
- VBS 2026 Tablecloth (9798384538189) or other disposable table covering
- Serrated knife (leader use only)
- Hair dryer (optional, leader use only)

ADVANCE PREPARATION

- Cut each pool noodle into 3-inch pieces (1 noodle piece for each paint color at the table)
- Option: Add some pool noodle pieces cut in half lengthwise to add a different design.
- Write *Jesus Is God's Promised Son* at the bottom of each piece of cardstock.
- Pour paint onto each paper plate. Provide several colors to be shared at each table.

LEADER TIP

For easy cleanup, provide each kid with a larger piece of paper to place under the items they are coloring or painting. If needed, use tape to keep paper in place.

FROM OUR TESTER

This was a fun and easy craft for preschoolers of all ages. This craft was enjoyed by all.

POOL NOODLE PAINTING (Free Art)

CONNECT

Say: "Jesus asked His disciples who they said He is. Peter answered Jesus by saying: 'You are God's Son.' As you make your painting, remember that Jesus is God's promised Son."

CREATE

1. Assist preschoolers in putting on painting smocks.
2. Demonstrate how to dip a pool noodle piece in paint and apply it to paper.
3. Provide each preschooler with a piece of cardstock that says *Jesus Is God's Promised Son*.
4. Encourage a preschooler to dip a pool noodle piece in paint and create her design. Remind her to use a different piece for each paint color.
5. Option: Provide kindergartners with their own plates of paint containing 3–4 colors. Suggest that kindergartners use the same pool noodle piece in different colors to mix colors.
6. Set pictures aside to dry. Use a hair dryer to speed up the drying process if needed.

JESUS ROCKS

CONNECT

Say: “Jesus asked His disciples ‘Who do people say I am?’ God let Peter know that Jesus is God’s Son. You are going to paint rocks today. Jesus’ name is on the rocks. Your rocks can help you remember that Jesus is God’s promised Son and He loves you.

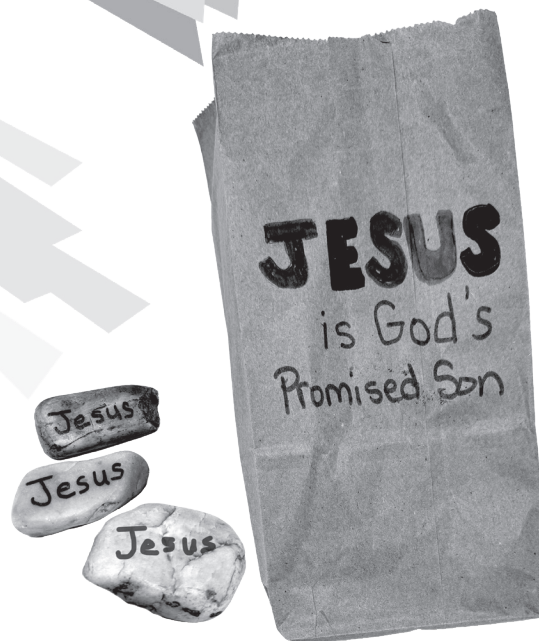

CREATE

1. Assist preschoolers in putting on painting smocks.
2. Guide each preschooler to select 2–3 rocks.
3. Invite a preschooler to paint her rocks with the glow-in-the-dark paint. Explain that she is not to paint the bottom of the rocks.
4. After preschoolers have finished painting the rocks, place rocks on wax paper to dry. Use a hair dryer to speed drying time.
5. Instruct a preschooler to decorate the outside of a paper bag. Place rocks in the bag once they have dried.
6. Discuss places they can place the rocks to remind them that Jesus is God’s promised Son.

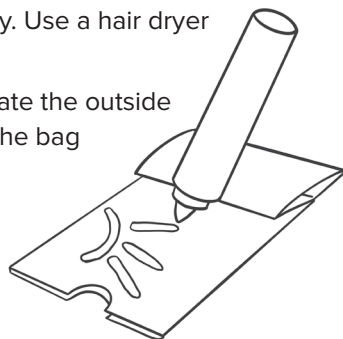

Option for younger preschoolers

- Use bright washable markers instead of paint.

Option for older preschoolers

- Write on separate rocks words or phrases from the theme verse or motto. Make each kid a complete set. Challenge kids to put the words in order.

GATHER SUPPLIES

- Smooth white rocks (2–3 per kid)
- Washable glow-in-the-dark or neon acrylic paints (light colors)
- Lunch-size paper bags (1 per kid)
- VBS 2026 Theme Stickers* (9798384538158)
- 1-inch foam paintbrushes
- Small bowls for paint
- Painting smocks
- Black permanent and washable markers
- Brown craft paper to cover tables
- Wax paper
- Disposable wipes
- Paper towels
- Hair dryer (optional, leader use only)

LEADER PREPARATION

- Wash rocks and let them dry.
- Cover tables with brown craft paper.
- Write *Jesus* on each rock in permanent marker.
- Option: For older preschoolers, write the name *Jesus* on the brown paper table covering in washable marker for preschoolers to copy. Write it at each seat.
- Place a sheet of wax paper at each kid’s spot.
- Pour a small amount of washable paint in each bowl. Test paint on one of your rocks to make sure the colors are light enough not to cover the writing.
- Place bowls and paintbrushes on tables for easy access.
- Set rocks out on the table where kids can easily see the selection.
- Have disposable wipes and paper towels available.

LEADER TIP

Make paint smocks using youth large t-shirts. Cut the t-shirts up the back in a straight line from the hem through the collar. Clip a clothespin to secure the t-shirt when it is placed on a kid.

DAZZLING KALEIDOSCOPE

CONNECT

Remind kids: “Our Bible verse this week tells us that Jesus is the Light of the world. Today you are going to make a kaleidoscope. A kaleidoscope uses color, light, and shapes to make something beautiful. As you look through your kaleidoscope remember that ‘Jesus said, “I am the light of the world.” John 8:12.’”



CREATE

1. Guide a preschooler to choose a color of construction paper for her kaleidoscope.
2. Encourage her to use crayons and stickers to decorate her kaleidoscope covering on one side only.
3. Help each kid attach his kaleidoscope covering to a 4-inch tube.
4. Assist a preschooler as she places a mirrored cardstock triangle in the middle of the tube. Help her use a piece of tape to secure the mirror paper to the tube in one or two spots.
5. Distribute a 5-by-5-inch square sheet of white cardstock to each kid.
6. Invite kids to decorate the paper using glue and sparkle confetti.
7. Demonstrate holding a kaleidoscope up to your eye to look at the patterns on the paper and turning it to see the patterns reflected in the mirror paper. Invite a preschooler to explore how light bounces off objects through his kaleidoscope.

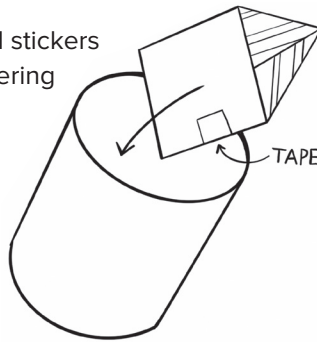

GATHER SUPPLIES

- ❑ 4-inch cardboard tube (1 per kid)
- ❑ Mirrored cardstock
- ❑ Small sparkle foil confetti
- ❑ Construction paper (various colors)
- ❑ White cardstock
- ❑ Crayons
- ❑ VBS 2026 Theme Stickers (9798384538158)
- ❑ Clear tape
- ❑ Glue
- ❑ VBS 2026 Tablecloth (9798384538189) or other table covering

ADVANCE PREPARATION

- Cut mirrored cardstock into 1 rectangle per kid: 3¾ inches by 4 inches each.
- Fold mirrored cardstock into thirds on the short side so that it is a 1¼-inch 3D triangle with the mirror side facing in. Secure triangle using clear tape.
- Cut construction paper into 4-inch-by-6-inch rectangles—1 per kid.
- Cut white cardstock into 5-inch-by-5-inch squares—1 per kid.
- Set construction paper squares, theme stickers, and crayons on tables for easy access.

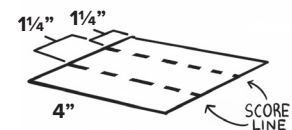

FROM OUR TESTER

Make sure you use small confetti for this craft.

Note: Confetti can be a choking hazard. Supervise young preschoolers carefully.

CRAFT STICK LANTERN

CONNECT

As preschoolers create their lanterns, point out that these lanterns will show really pretty light through the patterns they draw. Remind preschoolers that “Jesus said, ‘I am the light of the world.’” John 8:12.

CREATE

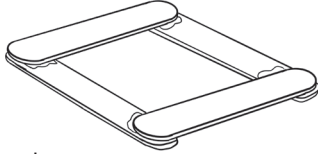
1. Guide preschoolers to color craft sticks using washable markers.
2. Encourage preschoolers to create designs on each piece of parchment paper.
3. Assist a kid as he attaches his parchment paper designs to the craft stick squares using a glue stick or mavalus tape. Secure parchment paper with tape once it has been glued. 
4. Help a kid attach squares together using duct tape to form a triangle shaped lantern.
5. Option: Attach washi tape over duct tape to add decoration to the lantern.
6. Place the lantern over a battery-operated tea light to show how the light shines through the lantern.

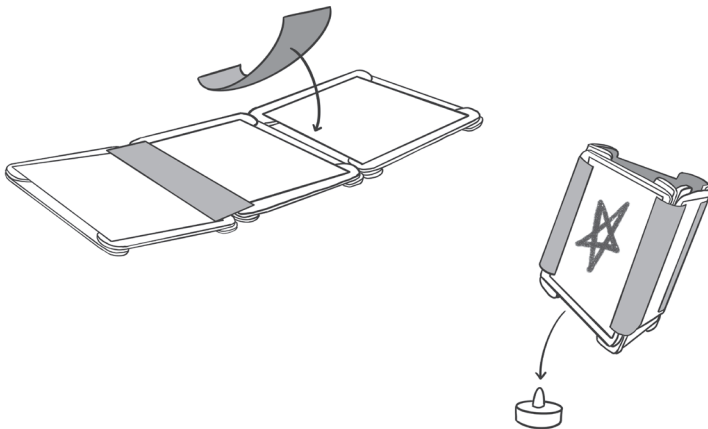

GATHER SUPPLIES

- Templates
 - “Square Template” (redemption files only, p. 1)
- Craft sticks (12 per kid)
- Parchment paper
- Duct tape—variety of colors
- Glue sticks
- Washable markers
- Washi tape
- Mavalus® tape
- Cool melt hot glue gun (leader use only)
- Battery-operated tea light (1 per kid)
- VBS 2026 *Tablecloth* (9798384538189) or other disposable table covering

ADVANCE PREPARATION

- Cut parchment paper into 5-by-5-inch squares (3 squares per kid)
- Make craft stick squares by hot gluing 4 craft sticks together (3 squares per kid). Use the “Square Template” to make squares even.
- Make a sample lantern.
- Cover the tables with tablecloths.

LEADER TIPS

Be sure top and bottom sticks do not extend past side sticks. Craft stick squares need to match.

Leave about 1/8 inch between squares when attaching them so they fold to make a lantern.

CRAFT PACK OPTION

Materials for a similar craft can be found in the VBS 2026 *Craft Stick Lantern Craft Pack* (9798384539841). Does not include battery-powered candles.

FROM OUR TESTER

Younger preschoolers struggle with coloring 12 craft sticks. Consider using pre-colored craft sticks or omitting Step 1.

JESUS IS GOD'S PERFECT SON



Today's Point
Jesus is God's perfect Son.

The Baptism of Jesus (*Matthew 3:13-17; Mark 1:1-11; John 1:29-34*)

John the Baptist was baptizing people who had chosen to follow God. Jesus went to see John the Baptist at the Jordan River. Jesus told John that He wanted to be baptized, but John didn't think he should baptize Jesus. John was confused. He baptized people who disobeyed God, but Jesus never disobeyed God! Jesus said, "Let Me be baptized. God says this is right." So John baptized Jesus. When Jesus came up out of the water, God's voice came from heaven. "This is My Son," the voice said. "I love Him, and I am very pleased with Him!"

DAY 2

GATHER SUPPLIES

- Watercolor paper
- Watercolor paints
- Cups of water
- Watercolor brushes
- Small bowls of salt
- Permanent marker
- Spoons
- Allergy alert
- VBS 2026 Tablecloth (9798384538189) or other disposable table covering

ADVANCE PREPARATION

- Write *Jesus is God's perfect Son* on a piece of paper for each kid in permanent marker.
- Place painting supplies on tables for easy access.
- Cover tables with tablecloths.
- Post an allergy alert mentioning that kids will be handling salt.

FROM OUR TESTER

Darker watercolor paints work better with this craft. The watercolor paints dry fast, so you need to apply the salt pretty quickly.

SALT PAINTING (Free Art)

CONNECT

Mention that when John baptized Jesus, John lowered Jesus under the water and then raised Him up. God said "This is My Son. I love Him, and I am very pleased with Him!"

Kids will paint with water to remind them that Jesus is God's Son and God loves Him and is very pleased with Him.

CREATE

1. Provide each kid with a piece of watercolor paper.
2. Encourage preschoolers to paint their entire sheet of paper with watercolor paints.
3. Demonstrate how to sprinkle a large spoonful of salt across the painting.
4. Guide preschoolers to observe how the paint reacts to the salt.

BAPTISM SCENE

CONNECT

Share: “Today we learned that Jesus never disobeyed God! Jesus said, ‘Let Me be baptized. God says this is right.’ So John baptized Jesus.”



CREATE

1. Distribute “Sun Templates.” Invite kids to color the “sun” using either an orange or yellow crayon.
2. As a kid completes her “sun” provide her with light blue construction paper. Encourage her to use a glue stick to attach her sun on the top left corner of the paper.
3. Guide a kid to place a small amount of glue on a small section of the bottom of the page (about $\frac{1}{4}$ of the page) and place different shades of crumpled blue tissue paper on the glue to create water. Continue process until the bottom of the page is covered.
4. After kids create “water,” distribute copies of the “Jesus and John Template” and allow kids to color those.
5. Guide kids to use glue to attach the “Jesus and John Template” to the paper so that they appear to be standing in the tissue paper “water.”

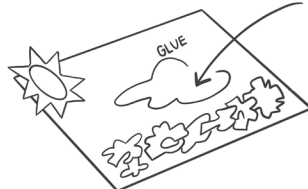
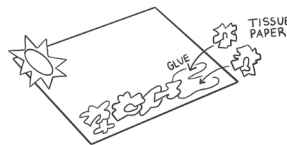
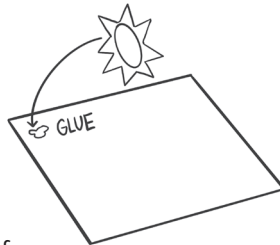

GATHER SUPPLIES

- Templates
 - “Sun Template”
 - “Jesus and John Template”
- Light blue construction paper
- White cardstock
- Variety of shades of blue tissue paper
- Bowls for cut tissue paper
- Glue sticks
- Orange and yellow crayons
- VBS 2026 *Tablecloth* (9798384538189) or other disposable table covering
- Disposable wipes
- Paper towels

ADVANCE PREPARATION

- Cut tissue paper into 1-inch squares.
- Option: Crumple paper to save time.
- Copy and cut one “Sun Template” and one “Jesus and John Template” for each kid.
- Cover tables with tablecloths.
- Place tissue paper in disposable bowls and place on tables for easy access. Be sure to mix shades in each bowl.
- Place orange and yellow crayons and glue sticks where kids can reach them.

LEADER TIP

Have disposable wipes and paper towels available. Many preschoolers will want to immediately remove glue from their hands.

FROM OUR TESTER

This was such a pretty craft!

Tie-Dye SUNCATCHERS

CONNECT

Ask: "Where did John baptize Jesus? That's right, in a river!"
As preschoolers craft with water, remind them that Jesus was baptized to obey God. In fact, Jesus always obeyed God!
Jesus is God's Son and God is very pleased with Him.

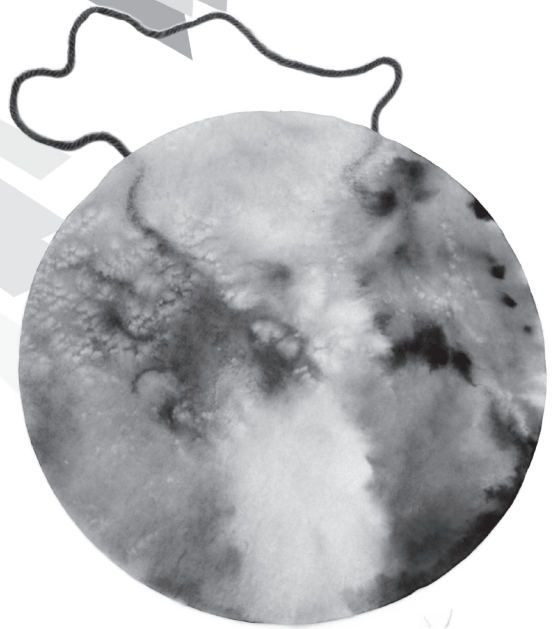

CREATE

1. Help each preschooler put on a paint smock.
2. Guide a kid to use markers to color one or two coffee filters. Suggest he use several bright colors and color the filter completely.
3. Encourage the preschooler to watch the colors spread and mix together as you spritz the coffee filter with water. (Older preschoolers may want the chance to spray the water themselves.)
4. Place the filter on paper towels to absorb extra water and begin to dry. Use a hair dryer on low to speed up the drying process.
5. While the filters are drying, distribute pieces of yarn to kids. Allow them to fold pieces of yarn in half. Once filters are dry, show preschoolers how they can tape the yarn to the back as a hanger.
6. Suggest that when they get home, preschoolers hang their suncatchers in a window so they can see how pretty the colors are when light comes through the window.

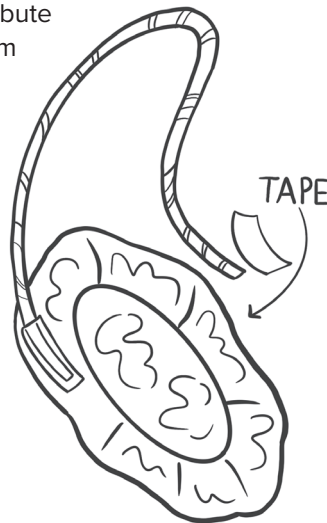
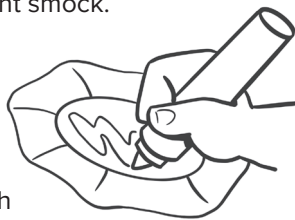

GATHER SUPPLIES

- ☐ White coffee filters (1–2 per kid)
- ☐ Paper
- ☐ Yarn or ribbon (24 inches per kid)
- ☐ Washable markers (various colors)
- ☐ New spray bottle
- ☐ Water
- ☐ Paper towels
- ☐ Disposable wipes
- ☐ Paint smock (1 per kid)
- ☐ Tape
- ☐ Scissors (leader use only)
- ☐ Hair dryer (leader use only)
- ☐ *VBS 2026 Tablecloth* (9798384538189) or other disposable table covering

ADVANCE PREPARATION

- Cut yarn into 24-inch pieces (1 per kid).
- Cover tables with tablecloths.
- Fill spray bottle with water.
- Place a coffee filter on a piece of paper and place at each kid's spot at the table.
- Place markers on tables for easy access. Be sure to include a variety of bright colors on each table.

FROM OUR TESTER

Preschoolers enjoyed using the spray bottles! If regular markers bleed more than kids like, let them try thin markers instead.

LIGHT BULB STRAW PAINTING

CONNECT

Share that sometimes when someone understands an important idea, they will use a picture of a light bulb to say they understand. Ask preschoolers to try to remember some important ideas from today's Bible story. (*Jesus always obeyed God; John baptized Jesus; Jesus is God's Son; God is very pleased with Jesus.*)



CREATE

1. Help the preschooler put on a paint smock.
2. Provide each kid with a "Light Bulb Template."
3. Explain to a preschooler that he will paint his picture using yellow paint and straws.
4. Use an eyedropper to drop paint in several places on paper.
5. Guide a kid to place his straw near the paint drop and blow through the straw to move the paint around the paper. Repeat until all paint drops have been spread.
6. Older preschoolers:
 - Instruct a kid to place her straw in a cup of yellow paint, place her fingertip over the top of the straw and lift the straw without removing her finger.
 - Tell her to place the straw over the paper and drop paint on the paper.
 - Guide her to place her straw near the paint drop and blow through the straw to move the paint around the paper.
 - Repeat the process until the light bulb is filled.

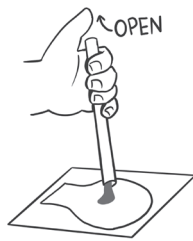

GATHER SUPPLIES

- Templates
 - "Light Bulb Template"
- Heavyweight cardstock
- Paint smocks
- Plastic straws (straight, not flexible) (1 per kid)
- Yellow washable tempera paint
- Small disposable cups/condiment cups
- Glue sticks
- Crayons or colored pencils
- VBS 2026 Tablecloth (9798384538189) or other disposable table covering
- Eye droppers

ADVANCE PREPARATION

- Print the "Light Bulb Template" on white cardstock for each kid.
- Pour a small amount of washable yellow tempera paint in small disposable cups. Add water to thin the paint. Make it thin but not watery.
- Cover tables with tablecloths.

LEADER TIPS

Condiment cups work well for this activity because they are more sturdy than paper cups and the lid can be placed on the cup covering remaining paint.

FROM OUR TESTER

This was a fun, messy craft. Younger preschoolers will try to suck the paint or blow spit through the straw. Consider letting them use eye droppers, but no straws. They can simply drop paint on the paper, but will not blow to move it around.

NOTE:

Some formulations of tempera paint contain eggs. Check your packaging and post an allergy alert if necessary.

JESUS IS THE POWERFUL SON OF GOD

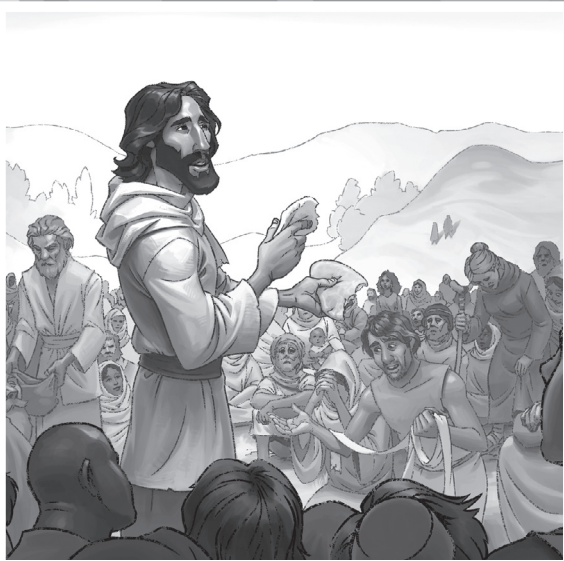

Today's Point

Jesus is the powerful Son of God.

Jesus Performed Miracles *(Matthew 15:29-39)*

Jesus went up a mountain. A lot of people came to see Him, including sick people. Since Jesus is God's Son, He could make the people well—and He did! Jesus felt bad for the people. They had been there for three days, and they didn't have anything to eat. Jesus didn't want to send them away hungry. Jesus asked the disciples how many loaves of bread they had. The disciples told Jesus they only had 7 loaves of bread and a few small fish. Jesus took the bread and the fish. Jesus thanked God for them and broke them into pieces. The disciples gave the food to the people. Even though Jesus started with very little food, there was enough for everyone to eat. There were 7 large baskets of leftovers! Jesus fed 4,000 men plus women and children that day.

DAY 3

GATHER SUPPLIES

- Templates
 - "Bible Marker Template"
- Cardstock
- Colored pencils
- Yarn (variety of colors)
- Hole punch
- Scissors (leader use only)
- VBS 2026 Theme Stickers (9798384538158)
- Option: self-adhesive contact plastic
- Option: watercolor colored pencils and paintbrushes
- Option: fish-shaped cookie cutters

ADVANCE PREPARATION

- Print and cut out a "Bible Marker Template" for each kid.
- Cut yarn in 8-inch strips.
- Place a Bible marker on the table for each preschooler.
- Place stickers, colored pencils, and yarn in the middle of the table for easy access.

FISH BIBLE MARKER (Free Art)

CONNECT

Say: "The Bible tells about Jesus feeding a large crowd of people with just seven loaves of bread and a few small fish in the books of Matthew and Mark. This is just one of many times the Bible tells us how Jesus can do things no one else can do. When you are finished making your Bible marker you can place it in your Bible at the book of Matthew where this story is found."

CREATE

1. Provide each kid with a Bible marker.
2. Encourage preschoolers to design their Bible markers using the colored pencils and VBS theme stickers on the table. Allow kindergartners to trace fish shapes on the blank side of their Bible markers.
3. Option: Allow older preschoolers to use watercolor pencils. After preschoolers are finished designing, allow them to lightly wet a paintbrush and blend the colors together.
4. Option: Laminate Bible markers. Cover Bible markers with self-adhesive contact plastic on both sides. Cut markers apart.
5. Punch a hole at the top of each Bible marker.
6. Encourage a preschooler to select a piece of yarn, fold it in half, and thread the center through the hole at the top of his marker. Assist him in pushing the ends of the yard through the loop and pulling them tight.

BASKET OF FOOD

CONNECT

As kids make their baskets of food, talk about how Jesus used 7 loaves of bread and a few small fish to feed 4,000 men plus women and children. Remind kids that Jesus thanked God for the bread and fish before He began to break them into pieces. Mention that preschoolers can thank God for their food, too.

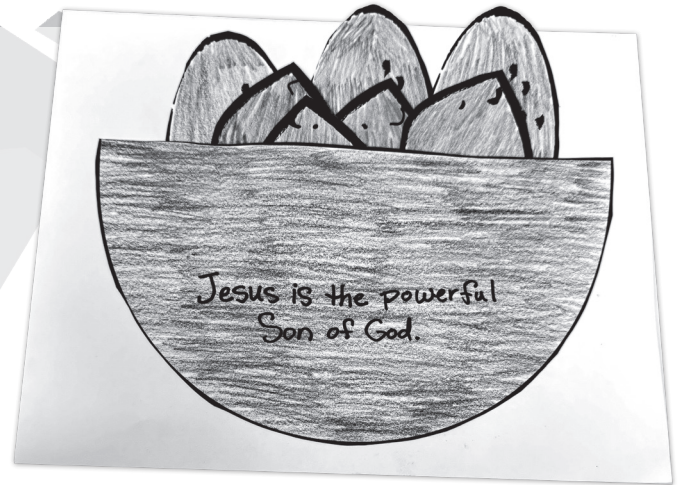

CREATE

1. Distribute a half circle to each preschooler. Encourage kids to color their half circles using brown and/or tan crayons. Suggest they add lines so it will look like a basket.

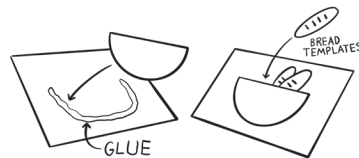

2. Guide a preschooler to glue the bottom edge of the half circle to the cardstock.

3. Allow kids to color the "Bread Templates" and "Fish Templates," then glue them inside the basket.

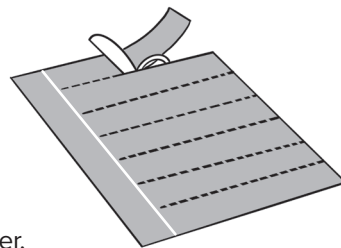

Option for older preschoolers:

- Demonstrate how to weave—under, over, push strip up against previous strip.
- Encourage preschooler to weave basket.
- Help a preschooler to use a glue stick to glue strips together on the ends of the cardstock.
- Glue the "Half Circle Template" to the woven cardstock and cut away the excess woven cardstock using the half circle as a guide.
- Glue the back of the half circle to a piece of cardstock so that the woven basket is facing out. Color and add the fish and bread as above.

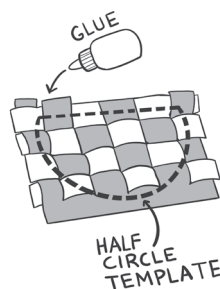
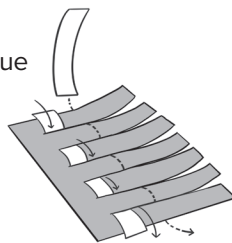

GATHER SUPPLIES

- Templates
 - "Bread Template"
 - "Fish Template"
 - "Half Circle Template"
- White cardstock
- Glue sticks
- Crayons (especially brown and/or tan)
- Option for older preschoolers:
 - Light brown cardstock (1 per kid)
 - Darker brown cardstock (1 per kid)
 - White cardstock (1 per kid)
 - Tape

ADVANCE PREPARATION

- Print and cut out the "Bread Template" on white cardstock (7 per kid).
- Print and cut out the "Fish Template" on white cardstock (3 per kid).
- Print and cut out a "Half Circle Template" for each kid. Write *Jesus is the powerful Son of God* on each half circle.
- Place glue sticks and crayons on tables for easy access.
- Option for older preschoolers:
 - For each kid, from the left edge of a piece of light brown cardstock, measure in 1½ inches and draw a line parallel to the left side (white line in the second sketch). Cut the rest of the cardstock into 1-inch strips from the right side, stopping at the line you just made (black lines in the second sketch). Tape the whole left side of the cardstock to the table.
 - Cut dark brown cardstock into 1½-inch vertical strips (6 per kid).
 - Provide several half paper plates.

LEADER TIPS

Place bread (7) and fish (3) in ziplock bags for easy distribution.

CONSTELLATION CUBE

CONNECT

Say: “Today you heard how Jesus has power to do things no one else can do. We get to see Jesus’ power every night because He made all the stars in the sky!” Explain that our minds kind of draw lines between the stars to show us shapes, like a dot-to-dot, and that those are called constellations. Show preschoolers the constellations on the cube and suggest that they can remember Jesus’ power when they play with their cubes.



ASSEMBLE

1. Distribute copies of the constellation cube. Instruct kids to decorate the cube with star stickers. They may choose to add stars to the constellations, or around them.
2. Help a preschooler to fold the template along the solid lines to form the cube shape.
3. Assist preschoolers in taping the seams on the cube to seal it shut.
4. Allow kids to enjoy gently tossing their cubes and seeing where they land. Suggest they count the number of stars on that side and hop that many times in place.

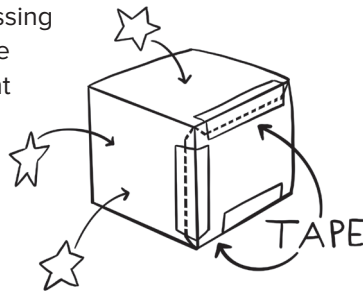
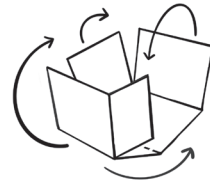
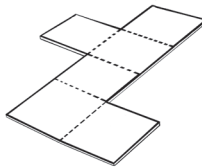

Tip: To make the cube more sturdy, add crumpled up paper to the inside.

GATHER SUPPLIES

- Template
 - “Constellation Cube Template”
- 11-by-17-inch cardstock
- Silver foil star stickers
- Tape
- Scissors

LEADER PREP

- Print and cut out one “Constellation Cube Template” for each kid on 11-by-17-inch cardstock.
- Score each copy of the template on the solid lines.

LEADER TIP

Consider printing white constellations on black cardstock to make this look more like the night sky. This option is only supported by some printers.

ALTERNATE OPTION

Materials for a similar craft can be found in the *VBS 2026 Constellation Cube Craft Pack* (9798384539872).

FROM OUR TESTER

This was a quick, easy craft.

STRING PAINTING

CONNECT

Say: “People were amazed as they watched Jesus heal people and feed a crowd with only a little food. These miracles helped people understand that Jesus is the powerful Son of God. Only God could do these things. No one else could!” Talk with preschoolers about the miracles Jesus performed as they make their string paintings.

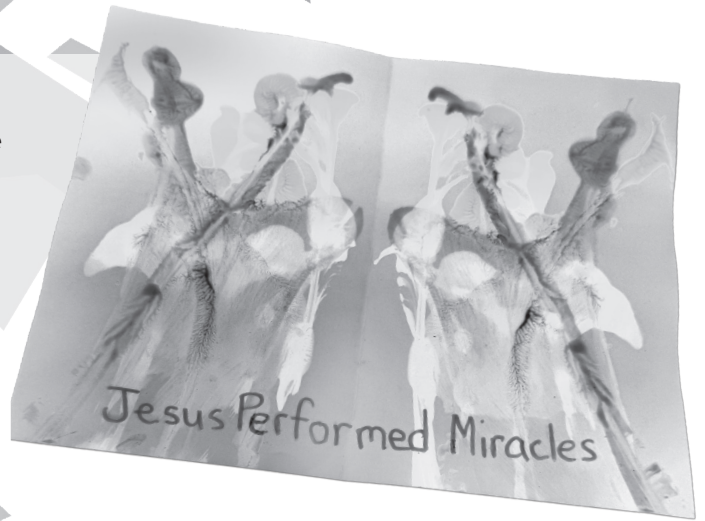

CREATE

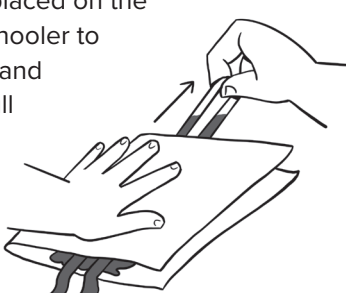
1. Assist preschoolers in putting on paint smocks.
2. Instruct a preschooler to drape a piece of string over a craft stick and to drop the ends of a piece of string into a cup of paint, submerging it. She may also choose to drop the entire piece of string into the paint and carefully remove it with a craft stick.
3. Guide her to lay the string on her paper. Be sure that part of the string is sticking off the bottom of the paper.
4. Once the string has been placed on the cardstock, direct the preschooler to fold her paper, place one hand on top of the paper, and pull the string out with her other hand.
5. Open the cardstock to see the design.
6. Repeat the process with different colors as desired until a final design is created.

Option for Younger Preschoolers:

- Place string on wax paper and paint the string. Use enough paint to cover the string while leaving a spot to hold it.
- Assist a kid in moving the string from the wax paper to the cardstock. Encourage preschoolers to place yarn in different places on their papers.
- Help a preschooler by placing your hand on the folded paper and encouraging him to pull the string out.

GATHER SUPPLIES

- Paint smocks
- Cardstock
- Glow-in-the-dark or neon washable paints
- String
- Brown craft paper to cover tables
- Condiment cups (1–2 per color, per table)
- Craft sticks (several per kid)
- Disposable wipes
- Paper towels
- Younger preschooler option:
 - 1 inch foam paintbrush (1 per color per table)
 - Wax paper

LEADER PREP

- Cut string into 18-inch lengths (1 string per cup of paint, or several per kid).
- Write *Jesus Performed Miracles* on the bottom of cardstock (1 piece per kid).
- Place paint in condiment cups. Thin with a small amount of water.

FROM OUR TESTER

This craft is very messy! Consider guiding young preschoolers especially to hold one end of the string in each hand and dip the middle in the paint. Help them push it under the paint with a craft stick. Proceed with the rest of the craft.

JESUS IS THE PROVEN SON OF GOD

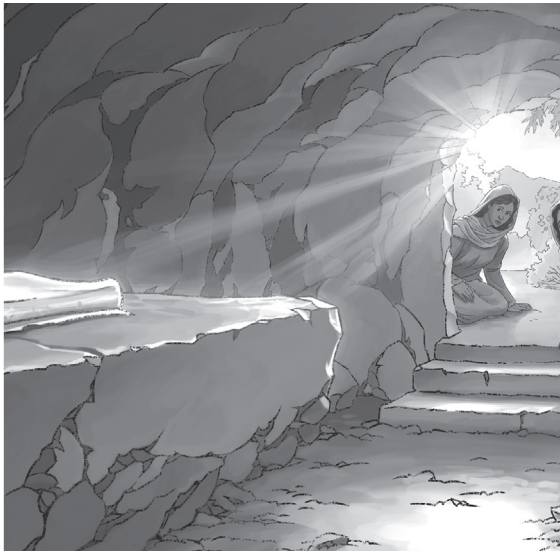

Today's Point
Jesus is alive!

Jesus Died and Rose to Life (Mark 14:43–16:7)

Jesus did many things that showed He is the powerful Son of God—things no one else could do. Some people did not like Jesus because of the things He was doing and teaching. They did not believe that Jesus was God's Son, so they wanted to stop Him. Jesus was arrested, put on trial, and nailed to a cross. When Jesus died, a Roman army officer who had been watching Jesus said, "This man really was God's Son!" After Jesus died, His body was placed in a tomb. Three days later, some women went to the tomb. When they got there, they saw that the stone had been rolled away. They went in but did not find Jesus' body. Instead, there was a man dressed in a white robe who said, "Don't be afraid. Jesus is not here. He is alive!"

GATHER SUPPLIES

- White cardstock (1 piece per kid)
- White crayon
- Watercolor paints
- Watercolor paintbrushes (1 per kid)
- Paint smocks
- Disposable cups
- Water
- Paper towels
- VBS 2026 Tablecloth (9798384538189) or other disposable table covering

ADVANCE PREPARATION

- Using a white crayon, write *Jesus is alive!* in the middle of each piece of cardstock.
- Add shapes such as a cross, a butterfly, and a smiley face to the paper for preschoolers to discover.
- Cover tables with a tablecloth.
- Set a piece of cardstock on the table at each preschooler's place.
- Place paint, paintbrushes, and disposable cups of water on the table for easy access.

FROM OUR TESTER

This was a fun and easy craft.

SURPRISE MESSAGE (Free Art)

CONNECT

Say: "Today we heard about something amazing Jesus did! We learned that three days after Jesus died, some women went to the tomb where Jesus was buried. When they got there it was empty. The women met a man who told them something very special about Jesus. As you paint today, you will discover the surprise message the women were told."

CREATE

1. Instruct a preschooler to dip her paintbrush in the water and then in the paint on the table to get a small amount of paint.
2. Explain to the kid that she will gently brush the paint over the paper in front of her.
3. As a preschooler discovers the surprise message, read it aloud for him. "Jesus is alive!" Encourage him to continue painting on his paper to discover what else is hidden.
4. Set artwork aside to dry.
5. Ask a preschooler to share the surprise message and pictures she discovered.

BUILD A SCENE

CONNECT

As preschoolers create an empty tomb remind them that when the women arrived at the tomb on the third day, they found it empty. Jesus was no longer inside because He is alive!



CREATE

1. Instruct a preschooler to hold the 2-inch ball of clay in his hand and begin making an indentation with the other thumb.
2. Keep pressing clay between the thumb and fingers, thinning the bottom and sides until they are about ¼-inch thick. Be sure the back side is rounded out.
3. Direct preschoolers to flatten one side against the table to be the bottom of the tomb.
4. Etch a preschooler's name on the bottom of her tomb using a toothpick and place it on wax paper.
5. Guide each preschooler to remove his ½-inch ball and begin to flatten it out to make a stone that partially covers the tomb opening. Set on the wax paper.
6. Glue the tomb to the cardboard and provide preschoolers with brown paint and paintbrushes. Allow them to paint their tombs. Guide them to paint the inside first, while the outside is a dry surface to hold, and then the outside.
7. Help a preschooler glue moss on the cardboard piece around the tomb.
8. Set aside to dry.

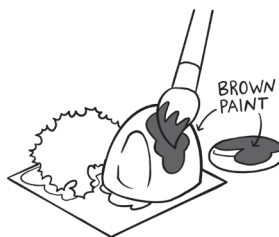
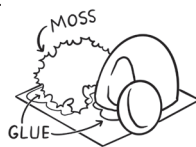

GATHER SUPPLIES

- Air-dry clay
- Cardboard (one 6-by-6-inch piece per kid)
- Paint smocks
- Faux moss
- Wax paper
- Brown paint
- 1-inch foam paintbrushes (1 per kid)
- Glue
- Condiment cups (1 per kid)
- Ziplock bags (1 per kid)
- Toothpick
- Allergy alert

LEADER PREP

- Roll air-dry clay into a 2 inch ball (1 per kid).
- Roll air-dry clay into a ½-inch ball (1 per kid).
- Place balls into a ziplock bag (1 per kid).
- Cut cardboard into 6-by-6-inch rectangles.
- Post an allergy alert stating that preschoolers will be handling faux moss.
- Make a sample.

LEADER TIP

For a more allergy-friendly option, consider using green shredded paper such as that used in gift wrapping.

FROM OUR TESTER

The finished project was super cool! The clay takes a while to air dry. You can paint it while wet, but preschoolers will need to wait until the next day to take them home.

LACED CROSS

CONNECT

Remind preschoolers that today they heard about something amazing Jesus did. On the third day after Jesus died on the cross and was placed in a tomb, the women discovered that Jesus was no longer in the tomb because He is alive! Say: “Let your cross be a reminder to you that Jesus loves you and that He is alive!”



CREATE

1. Direct preschoolers to choose a cross from the table.
2. Demonstrate for preschoolers how to weave the yarn through the holes in their cross, pulling tight so that the knot keeps the yarn from pulling through.
3. Provide assistance to preschoolers as needed.
4. Once the cross is laced, suggest each kid decorate his cross using markers and adhesive gems. Encourage kids to use markers on the cardstock side of the cross so that they won't smear.

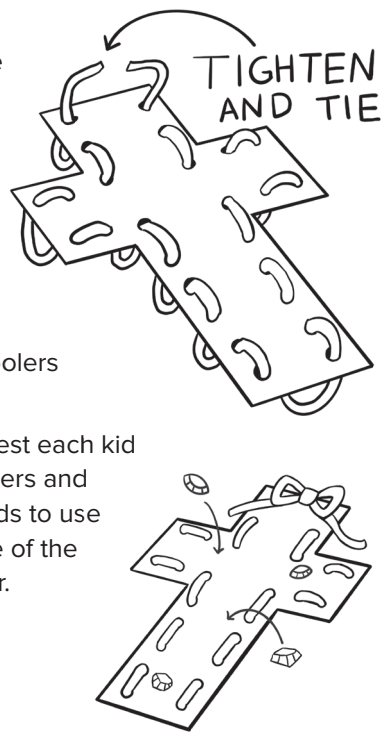

GATHER SUPPLIES

- Template
 - “Cross Template”
- Foam craft sheets (one 8½-by-5½-inch sheet per kid in a variety of colors)
- Cardstock (in colors that match the foam sheets, 1 per kid)
- Tipped lacing yarn (one 28-inch piece per kid)
- Glue sticks
- Heavy duty hole punch
- Sheets of adhesive round gems
- Washable markers

LEADER PREP

- Trace the “Cross Template” on foam sheets and cut out. You will need one for every kid. Suggestion: Make several extras per color to allow preschoolers to choose the color cross they prefer.
- Trace the cross on cardstock and cut out. One for each foam cross.
- Glue crosses together.
- Use a hole punch to make holes around the edge of cross. Place holes about an inch apart. Be careful not to punch too close to the edge.
- Write *Jesus is Alive!* on the cardstock side of each cross.
- Option: Allow kindergartners to copy the words themselves from a poster you create.
- Tie a knot in the end of each piece of yarn.
- Place crosses and lacing yarn in the middle of the table for each kid.
- Cut sheets of adhesive gems into strips and place strips of gems in disposable cups and place on the table for easy access.

FROM OUR TESTER

This was a quick and easy craft. A regular hole punch sticks and the foam tears. It requires a sturdy, strong hole puncher.

EMPTY TOMB SILHOUETTE

CONNECT

Say: "Today we learned that Jesus died on a cross. Three days after Jesus died, some women went to the tomb where Jesus was buried. When they got there they found it empty. They went in but did not find Jesus' body. Instead, there was a man dressed in a white robe who said, "Don't be afraid. Jesus is not here, He is alive! Go and tell His disciples."



CREATE

1. Assist preschoolers in placing a "Tomb Template" on the sticky side of a piece of contact paper.
2. Place a "Jesus is Alive" strip beneath the tomb and rock.
3. Place pieces of cellophane on the contact plastic around the empty tomb. Don't forget to fill the empty space in the doorway of the tomb.
4. Place a sheet of contact plastic on top of the design created by a preschooler, sticky side down.
5. Punch a hole at the top of the mosaic, one inch from each side.
6. Guide preschoolers to thread yarn in the holes. Tie knots on each side for preschoolers.

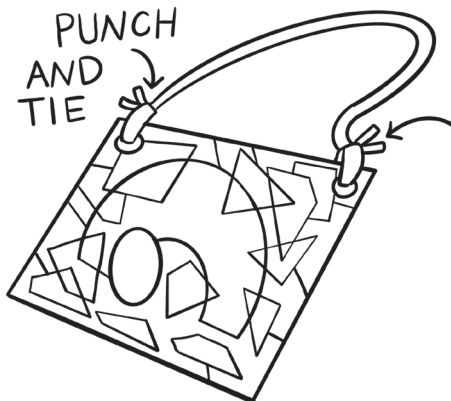
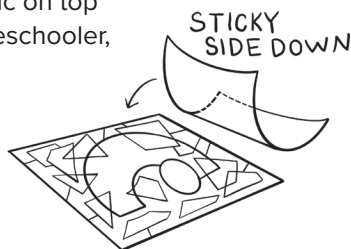
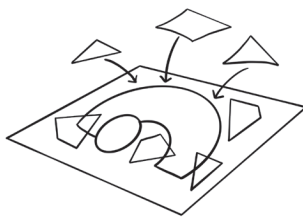
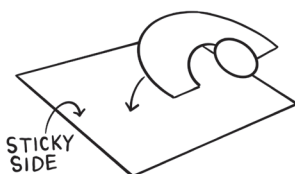

GATHER SUPPLIES

- Template
 - "Tomb Template"
- White cardstock
- Black cardstock
- Paper
- Cellophane pieces (4 colors)
- Self-stick contact plastic (two 6-by-6 squares per kid)
- Paper plates (1–2 per table)
- Heavy duty hole punch
- Yarn
- Double sided tape
- Scissors (leader use only)

ADVANCE PREPARATION

- Print a "Tomb Template" on white cardstock and cut it out.
- Trace and cut out one tomb from black cardstock for each kid.
- Write *Jesus is Alive!* on small strips of paper.
- Cut pieces of cellophane into 3-by-3-inch squares for younger preschoolers, and into random smaller shapes for kindergartners.
- Place cellophane pieces on paper plates on tables for easy access.
- Remove backing from one piece of contact paper per kid. Attach it to the table sticky-side-up using double-sided tape.
- Cut yarn into 24-inch pieces (1 per kid).

CRAFT PACK OPTION

Materials for a similar craft can be found in the *VBS 2026 Empty Tomb Silhouette Craft Pack* (9798384539889).

FROM OUR TESTER

Preschoolers will enjoy the final product! If you have trouble finding cellophane in multiple colors, consider substituting with tissue paper.

JESUS IS GOD'S PLAN FOR FORGIVENESS



Today's Point

Jesus is God's plan for forgiveness.

Peter Preached about Jesus (Acts 2)

Followers of Jesus were all together in one place for a celebration. While they were there, God helped them speak in many different languages so they could tell people about Jesus.

Peter and the other disciples stood up in front of the crowd. Peter reminded the people that they saw Jesus do things no one else could do. These things proved that Jesus is God's Son. But just as God knew would happen, some people did not like Jesus and killed Him. Peter reminded the people that Jesus came back to life.

As the people listened to Peter, they were sad. They knew they had disobeyed God (sinned). The people were sorry they had disobeyed God. They wanted to do what God wanted them to do. That day, about 3,000 people decided to become followers of Jesus!

DAY 5

GATHER SUPPLIES

- Templates
 - "Jesus Is God's Plan for Forgiveness Template"
 - "Peter Preached about Jesus Template"
- Jumbo craft sticks (6½ inches, 7 per kid)
- Adhesive labels (5-by-4½ inches, 1–2 per kid) (or regular paper and glue)
- Colored pencils
- Craft knife (leader use only)
- Quart-size ziplock bags (1 per kid)
- Painter's tape
- Glue sticks

LEADER PREP

- Print one copy of the "Jesus Is God's Plan for Forgiveness Template" on an adhesive label for each kid.
- Place 7 craft sticks side-by-side. Use painter's tape to tape them together, 1 set of 7 for each kid. Place each set in a ziplock bag.
- Place colored pencils on tables for easy access.
- Option for older preschoolers: Print copies of the "Peter Preached about Jesus Template" for the other side of the puzzle.

FROM OUR TESTER

This was a fun, cute craft.

CRAFT STICK PUZZLE (Free Art)

CONNECT

Talk about today's Bible story. Peter reminded people that Jesus was God's Son. They had seen Jesus do things no one else could. He healed people who were sick, He fed hungry people with a small amount of food, and He died and came back to life. Jesus is God's plan for forgiveness.

CREATE

1. Provide preschoolers with the "Jesus Is God's Plan for Forgiveness Templates."
2. Encourage kids to color the templates using the colored pencils on the table
3. When a kid finishes coloring her template, provide her with a bag of prepared craft sticks. Assist her in peeling off the adhesive label and attaching it to the front (non-taped) side of the craft sticks.
4. Remove the painter's tape from the back of the sticks and use the craft knife to cut the label apart between the craft sticks. Encourage preschoolers to use extra time to put the puzzles together before storing them in ziplock bags.
5. Option for older preschoolers:
 - Provide kids with a second label and encourage them to color the picture of Peter preaching to the people.
 - Attach the picture to the back of craft sticks and cut apart using the craft knife.

GLITTER ART

CONNECT

Briefly talk about today's Bible story. Mention that Peter preached about Jesus and everything Jesus' helpers saw Him do. Point out that Jesus' name starts with the letter *J*. Share that today kids will create a piece of glitter art using the letter *J* to remind them that Jesus is God's plan for forgiveness. Jesus is the Light of the world!

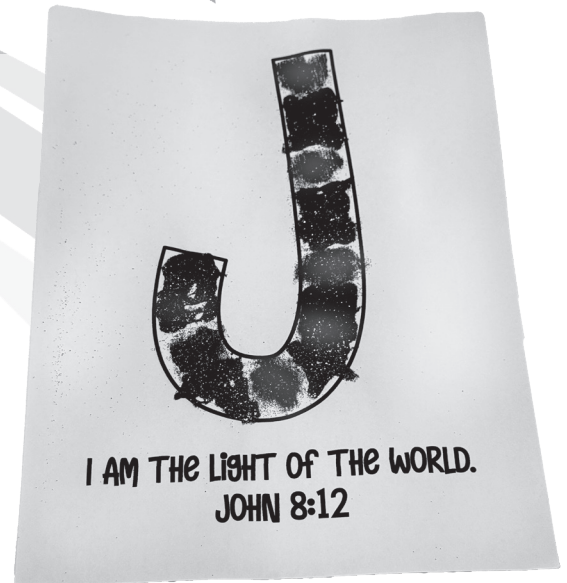

CREATE

1. Distribute a copy of the "Letter *J* Template" to each kid.
2. Assist a kid in "painting" a thin layer of glue on a small section of the *J* with a foam paintbrush.
3. Direct the kid to take a pinch of colored glitter and sprinkle it on top of the glue.
4. Repeat the process until the *J* is completely covered.
5. Encourage a preschooler to be creative. Suggest she use different colors. Be sure to cover all the glue with the glitter.
6. Assist a kid in lifting his paper and shaking off the excess glitter into a tub.

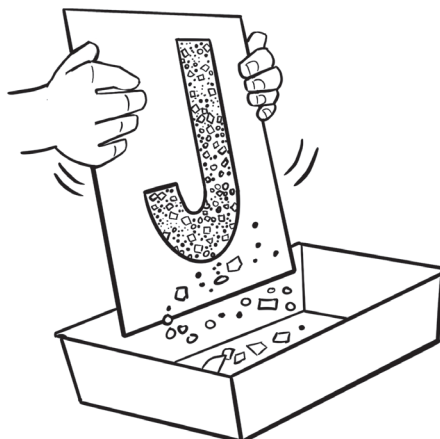
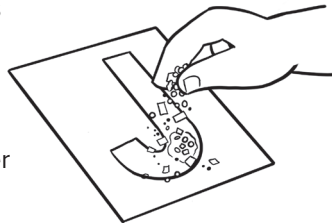
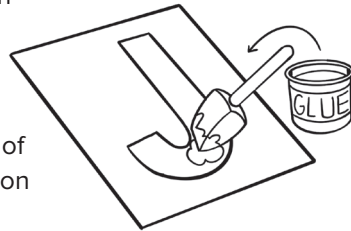

GATHER SUPPLIES

- Template
 - "Letter *J* Template"
- Heavyweight cardstock (1 piece per kid)
- School glue
- 1-inch foam paintbrushes (1 per kid)
- Colored glitter (a variety of bright colors)
- Disposable bowls
- Plastic spoons
- Washable markers
- Condiment cups with lids
- Tub for excess glitter

LEADER PREP

- Print a copy of the "Letter *J* Template" for each kid on cardstock.
- Place glitter in condiment cups. Cover with lids until needed.
- Mix glue with water to make a thin paint.
- Pour the glue mixture into disposable bowls.

FROM OUR TESTER

Easy and fun craft!

Note: Glitter can be a choking hazard. Supervise young preschoolers carefully.

ILLUMINATION STATION MAGNET

CONNECT

As preschoolers make their magnets talk about what they learned about Jesus this week at Illumination Station. Mention such truths as: Jesus is God's Son; Jesus never disobeyed God; Jesus has the power to do things no one else can do; Jesus is alive; and Jesus is God's plan for forgiveness.

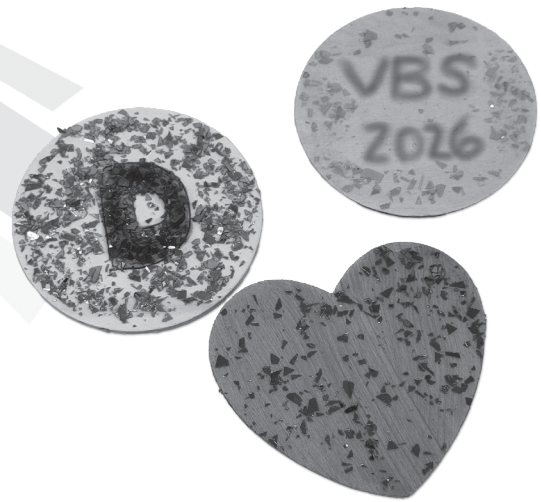

CREATE

1. Invite a preschooler to choose a shape for her magnet.
2. Supervise preschoolers as you encourage them to draw a picture on their shape with permanent marker of something they want to remember about Illumination Station. Talk about what they learned this week.
3. Guide a preschooler to apply a thin layer of paint over his picture on the wooden shape.
4. While paint is wet, sprinkle foil confetti over the paint.
5. Set aside to dry. Use a hair dryer to speed up the drying process, if needed.

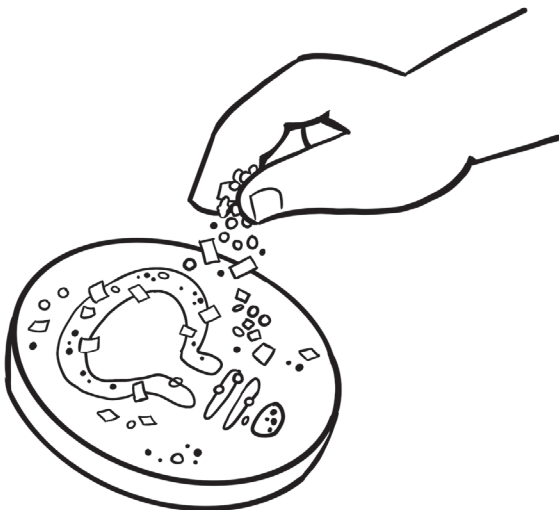

GATHER SUPPLIES

- Small wood or foam shapes (such as circles, stars, and hearts) (1 per kid, provide extras of each shape to allow preschoolers to choose)
- Washable glow-in-the-dark or neon acrylic paints
- Permanent markers
- Foam paintbrushes (1 inch, 1–2 per paint color)
- Self-adhesive magnets
- Sparkle foil confetti
- Condiment cups
- Wax paper
- VBS 2026 Tablecloth* (9798384538189) or other disposable table coverings
- Hair dryer (optional, leader use only)

LEADER PREP

- Attach a magnet to the back of each shape.
- Put paint in condiment cups. Add 2–3 drops of water to thin the paint.
- Cover tables with tablecloths.
- Place wax paper at each kid's work station.
- Place wooden shapes on a table
- Place paints and paintbrushes in the middle of the table for easy access

TIP

Consider using *VBS 2026 Sticky Foam Shapes* (9798384538134) and only applying glue and confetti or glitter to make them shine.

FROM OUR TESTER

Great souvenir piece! Use permanent markers or dark ink so it will show through the paint.

Note: Confetti and glitter can be choking hazards. Supervise young preschoolers carefully.

SCRATCH ART PICTURE FRAME

CONNECT

Say: "This week we have been learning that 'Jesus said, "I am the light of the world."' It has been fun shining a light on who Jesus is." Remind preschoolers that Jesus is God's promised Son, God's perfect Son, God's powerful Son, God's proven Son, and God's plan for forgiveness.

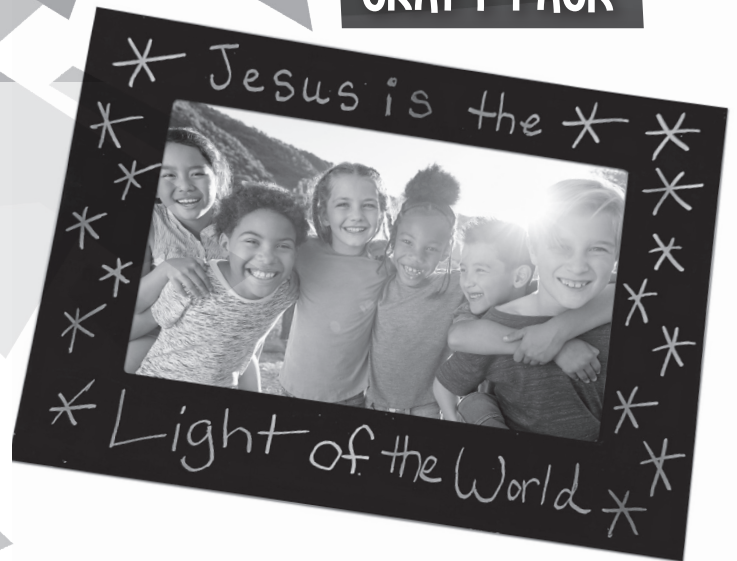

CREATE

1. Demonstrate coloring picture frames in random stripes and patterns using various colors and pressing hard to leave plenty of color on the frame.
2. Direct preschoolers to make sure all of the cardstock is heavily colored.
3. Guide a preschooler to paint a layer of black paint over the colored paper. Use a hair dryer to speed up the drying process.
4. Once paint is dry, guide a preschooler to gently use the end of a stick to scratch designs in the black paint, revealing the color beneath. Warn preschoolers to be gentle so the paper won't tear.
5. Using double-sided tape, attach a picture taken previously during the week in the middle of the cardstock.

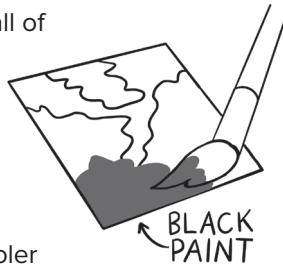
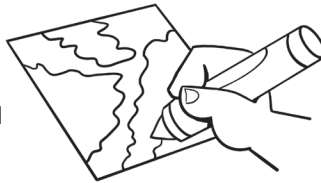

BLACK PAINT

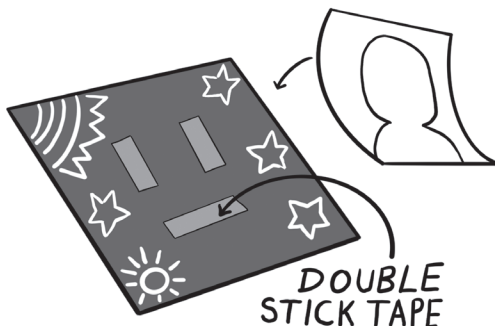
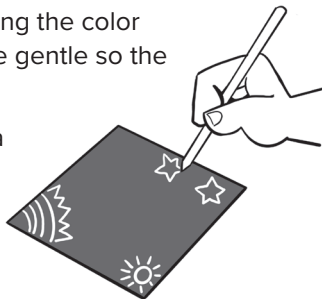

DOUBLE STICK TAPE

GATHER SUPPLIES

- Heavyweight cardstock (½ piece per kid)
- Neon crayons
- 1-inch foam paintbrushes (1 per kid)
- Black craft paint
- Dish soap
- Condiment cups
- Wax paper
- Thin sticks with blunt ends (such as chopsticks or the ends of thin paintbrushes)
- Double-sided tape
- Scissors
- Hair dryer (leader use only)
- VBS 2026 Tablecloth (9798384538189) or other disposable table coverings

ADVANCE PREPARATION

- Take a picture of each kid during the week to add to a picture frame. Bring developed photos ready to add to frames.
- Cut cardstock in half, ½ piece per every kid (8½ by 5½ inches).
- Pour paint and 3–4 drops of dish soap in condiment cups. Mix and place lids on cups until needed.
- Cover the table with a tablecloth.

CRAFT PACK OPTION

Materials for a similar craft can be found in the VBS 2026 Scratch Art Frame Craft Pack (9798384539865).

FROM OUR TESTER

This would make a great VBS memory piece. A heavy amount of crayon needs to be applied for the artwork to appear.

CRAFT PACK OPTIONS

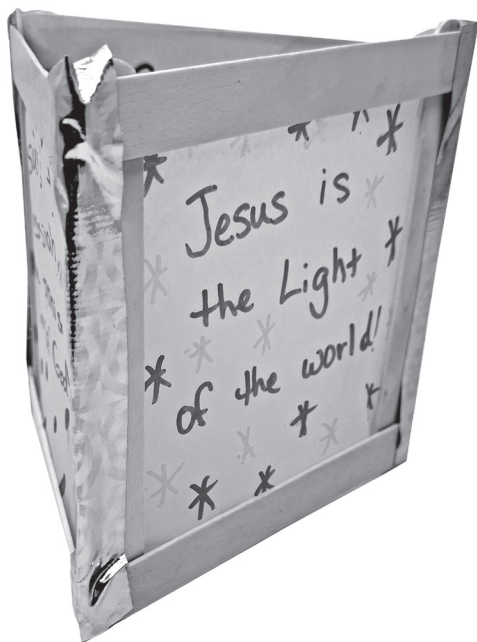

**VBS 2026 CRAFT STICK LANTERN
CRAFT PACK**
(Package of 10)
(9798384539841)



**VBS 2026 CONSTELLATION CUBE
CRAFT PACK**
(Package of 10) (9798384539872)



**VBS 2026 EMPTY TOMB SILHOUETTE
CRAFT PACK**
(Package of 10)
(9798384539889)

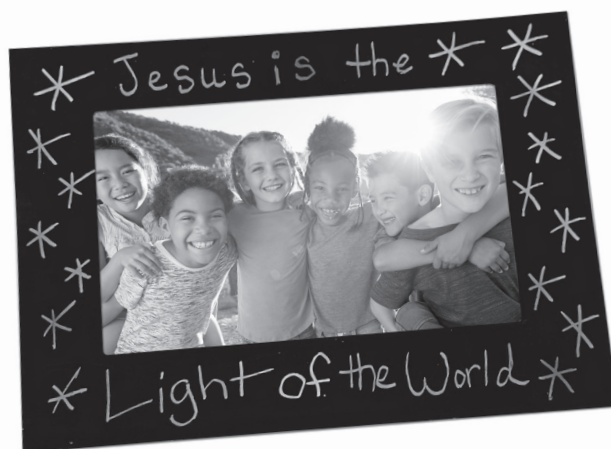

**VBS 2026 SCRATCH ART FRAME
CRAFT PACK**
(Package of 10)
(9798384539865)

PRESCHOOL CRAFT SUPPLIES

EVERYDAY SUPPLIES

- Cardstock (various colors)
- Colored pencils
- Construction paper (various colors)
- Crayons
- Disposable cups/condiment cups and bowls
- Foam paintbrushes (for painting and gluing)
- Glue, glue sticks, or glue dots
- Hole punch
- Markers (permanent and washable)
- Paints
- Painting smocks
- Paper plates
- Paper towels
- Scissors (adult and kid)
- Tape (clear, packing, and masking)
- Disposable wipes (for cleanup)
- VBS 2026 Tablecloths (9798384538189) or other table covering
- VBS 2026 Theme Stickers (9798384538158)

CRAFT PACKS

Optional craft pack activity suggestions are included. Each pack contains everything needed for ten kids except basic items such as markers, scissors, and glue. If a craft utilizes a light-up element such as a tea light, that is also not included in the pack.

- VBS 2026 Craft Stick Lantern Craft Pack (9798384539841)
- 2026 Constellation Cube Craft Pack (9798384539872)
- VBS 2026 Empty Tomb Silhouette Craft Pack (9798384539889)
- VBS 2026 Scratch Art Frame Craft Pack (9798384539865)

DAY 1 JESUS IS GOD'S PROMISED SON

POOL NOODLE PAINTING

- Washable glow-in-the-dark paints
- Pool noodles (different shapes, if available)
- Serrated knife (leader use only)
- Hair dryer (optional, leader use only)

JESUS ROCKS

- Smooth white rocks (2–3 per kid)
- Washable glow-in-the-dark or neon acrylic paints (light colors)
- Lunch-size paper bags (1 per kid)
- Brown craft paper to cover tables
- Wax paper
- Hair dryer (leader use only)

DAZZLING KALEIDOSCOPE

- 4-inch cardboard tube (1 per kid)
- Mirrored cardstock
- Small sparkle foil confetti

CRAFT STICK LANTERN

- Templates
 - “Square Template”
- Craft sticks (12 per kid)
- Parchment paper
- Duct tape—variety of colors
- Washi tape
- Mavalus® tape
- Cool melt hot glue gun (leader use only)
- Battery-operated tea light (1 per kid)

DAY 2 JESUS IS GOD'S PERFECT SON

SALT PAINTING

- Watercolor paper
- Watercolor paints
- Cups of water
- Watercolor brushes
- Small bowls of salt
- Spoons
- Allergy alert

BAPTISM SCENE

- Templates
 - “Sun Template”
 - “Jesus and John Template”
- Light blue construction paper
- Variety of shades of blue tissue paper
- Orange and yellow crayons

TIE-DYE SUNCATCHERS

- White coffee filters (1–2 per kid)
- Yarn or ribbon (24 inches per kid)
- New spray bottle
- Water
- Hair dryer (leader use only)

LIGHT BULB STRAW PAINTING

- Templates
 - “Light Bulb Template”
- Heavyweight cardstock
- Plastic straws (straight, not flexible) (1 per kid)
- Yellow washable tempera paint
- Eyedroppers

DAY 3

JESUS IS THE POWERFUL SON OF GOD

FISH BIBLE MARKER

- Templates
 - “Bible Marker Template”
- Yarn (variety of colors)
- Hole punch
- Option: self-adhesive contact plastic
- Option: watercolor colored pencils and paintbrushes
- Option: fish-shaped cookie cutters

BASKET OF FOOD

- Templates
 - “Bread Template”
 - “Fish Template”
 - “Half Circle Template”
- Option for older preschoolers:
 - Light brown cardstock (1 per kid)
 - Darker brown cardstock (1 per kid)

CONSTELLATION CUBE

- Template
 - “Constellation Cube Template”
- 11-by-17-inch cardstock
- Silver foil star stickers

STRING PAINTING

- Glow-in-the-dark or neon washable paints
- String
- Brown craft paper to cover tables
- Craft sticks (several per kid)
- Option for younger preschoolers:
 - Wax paper

DAY 4

JESUS IS THE PROVEN SON OF GOD

SURPRISE MESSAGE

- White crayon
- Watercolor paints
- Watercolor paintbrushes (1 per kid)
- Water

BUILD A SCENE

- Air-dry clay
- Cardboard (one 6-by-6-inch piece per kid)
- Faux moss
- Wax paper
- Ziplock bags (1 per kid)
- Toothpick
- Allergy alert

LACED CROSS

- Template
 - “Cross Template”
- Foam craft sheets (one 8½-by-5½-inch sheet per kid in a variety of colors)
- Cardstock (in colors that match the foam sheets, 1 per kid)
- Tipped lacing yarn (one 28-inch piece per kid)
- Sheets of adhesive round gems

EMPTY TOMB SILHOUETTE

- Template
 - “Tomb Template”
- Cellophane pieces (4 colors)
- Self-stick contact plastic (two 6-by-6 squares per kid)
- Heavy duty hole punch
- Yarn
- Double-sided tape

DAY 5

JESUS IS GOD’S PLAN FOR FORGIVENESS

CRAFT STICK PUZZLE

- Template
 - “Jesus Is God’s Plan for Forgiveness Template”
 - “Peter Preached about Jesus Template”
- Jumbo craft sticks (6½ inches, 7 per kid)
- Adhesive labels (5-by-4½ inches, 1–2 per kid) (or regular paper and glue)
- Craft knife (leader use only)
- Quart-size ziplock bags (1 per kid)
- Painter’s tape

GLITTER ART

- Template
 - “Letter J Template”
- Heavyweight cardstock (1 piece per kid)
- Colored glitter (a variety of bright colors)
- Plastic spoons
- Tub for excess glitter

ILLUMINATION STATION MAGNET

- Small wood or foam shapes (such as circles, stars, and hearts) (1 per kid, plus extras)
- Washable glow-in-the-dark or neon acrylic paints
- Self-adhesive magnets
- Sparkle foil confetti
- Wax paper
- Hair dryer (leader use only)

SCRATCH ART PICTURE FRAME

- Heavyweight cardstock
- Neon crayons
- Black craft paint
- Dish soap
- Wax paper
- Heavyweight cardstock
- Hair dryer
- Thin sticks with blunt ends (see p. 26)
- Double-sided tape

TEMPLATES

Day 2: Sun Template

ACCESS YOUR FILES ONLINE

You can access your templates online by using the following instructions:

- Go to my.lifeway.com/redeem and register or log in.
- Enter this unique code to download all printable items: **RNLQXN4D7PTT**
- Follow the directions to download your resources on any compatible device. Unless otherwise noted, make sure to print at “Actual Size” or 100% to get the intended size.
- For customer support, call 866.627.8553.

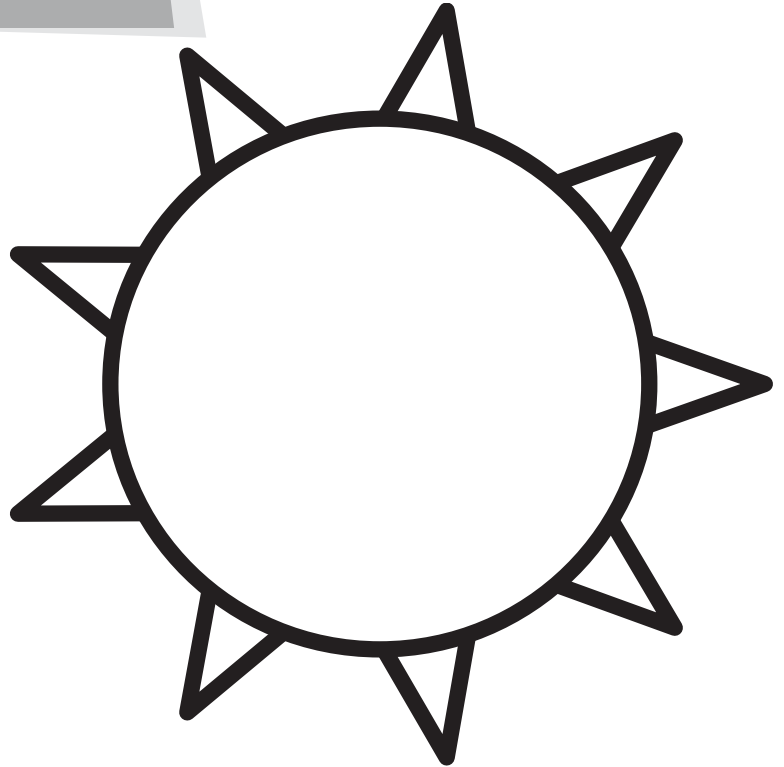

Day 2: Jesus and John Template

JESUS IS GOD'S PERFECT SON

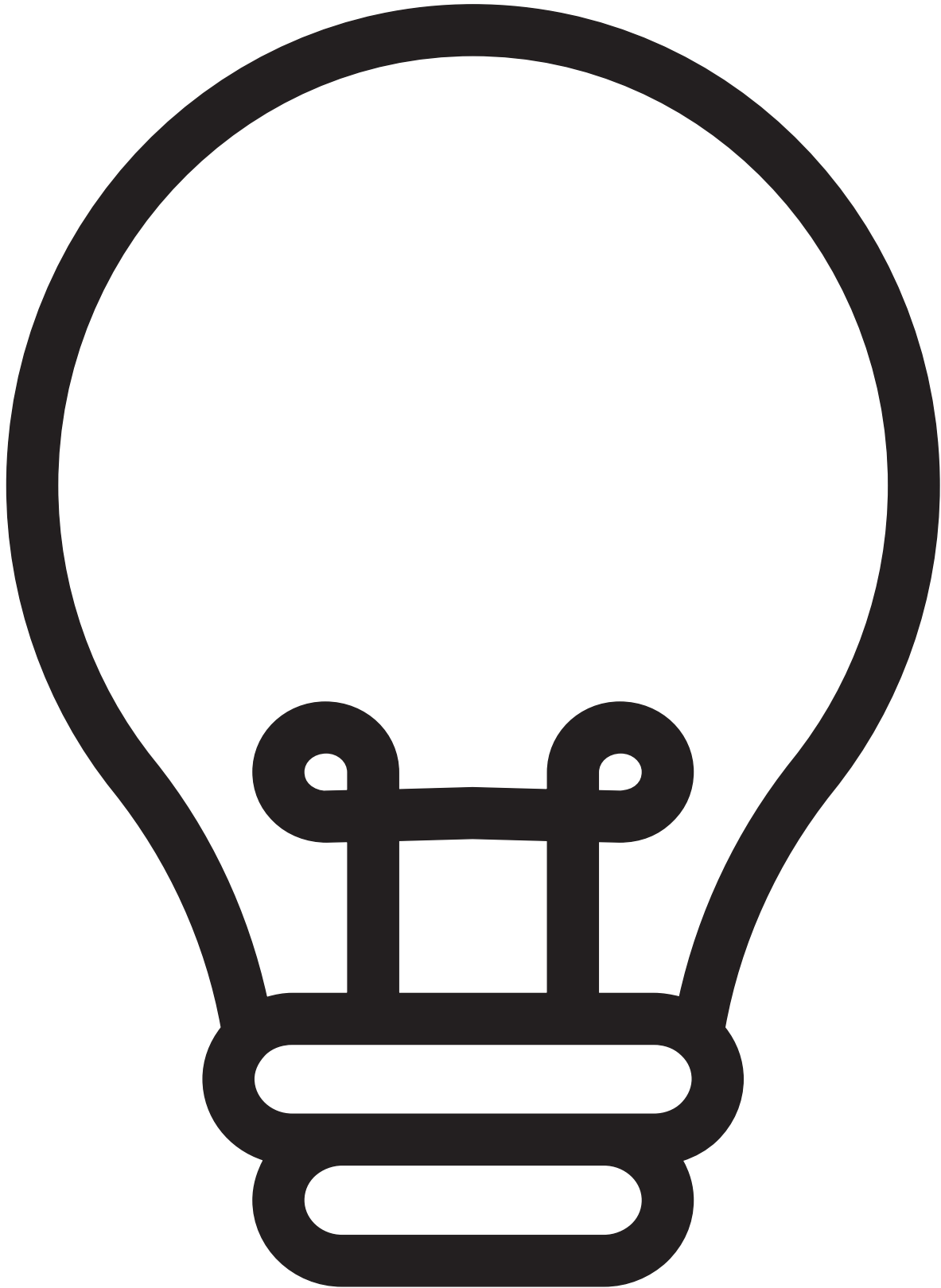

Day 3: Bread Template

JESUS is
The
POWERFUL
SON OF GOD

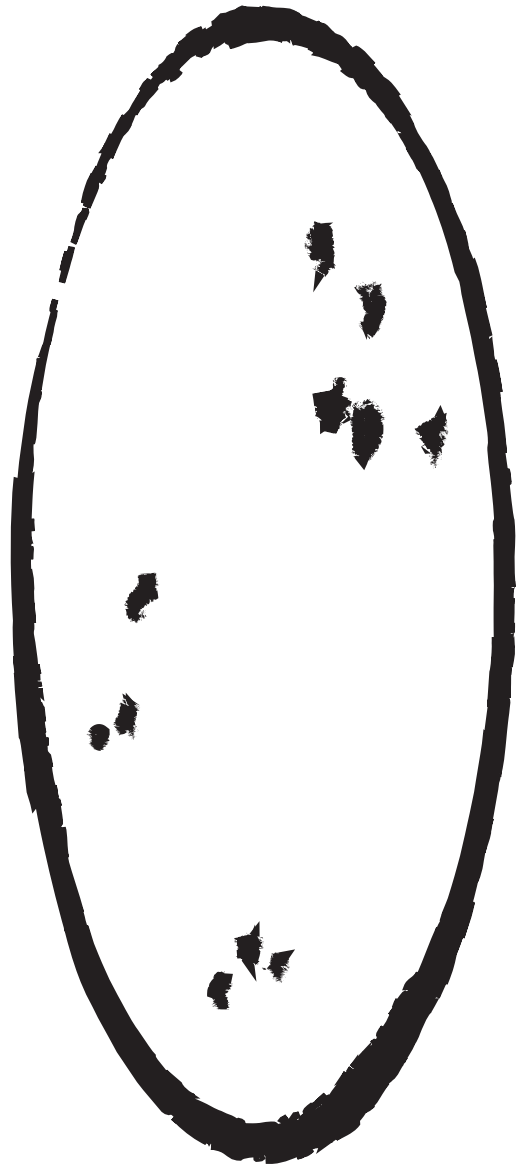

Day 3: Bible Marker Template
enlarge 114%

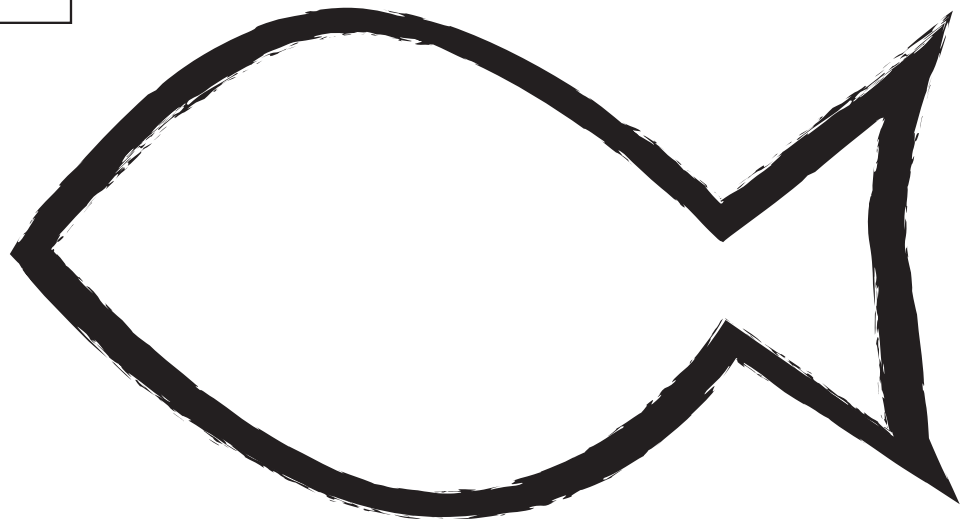

Day 3: Fish Template

Day 4: Cross Template
enlarge 123%

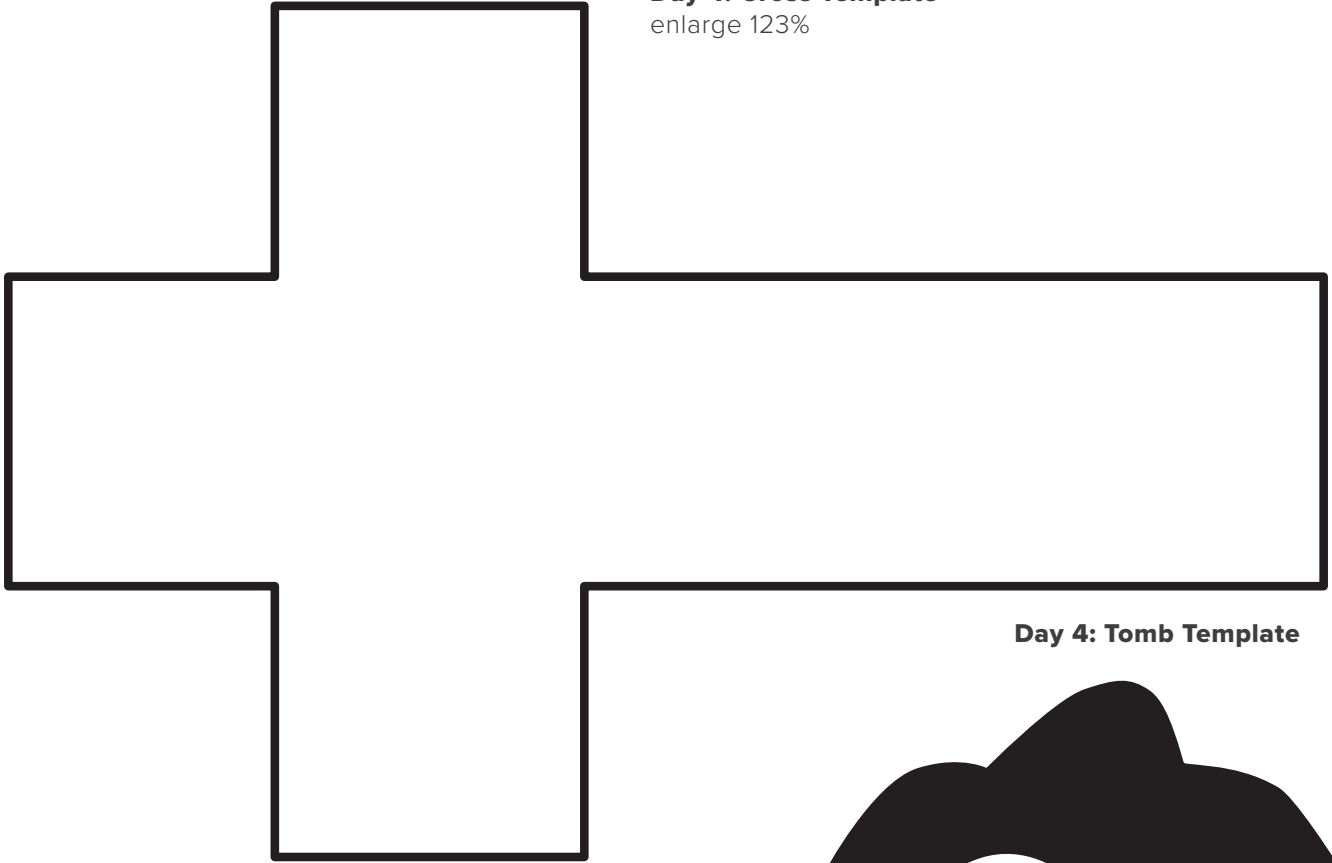

Day 4: Tomb Template

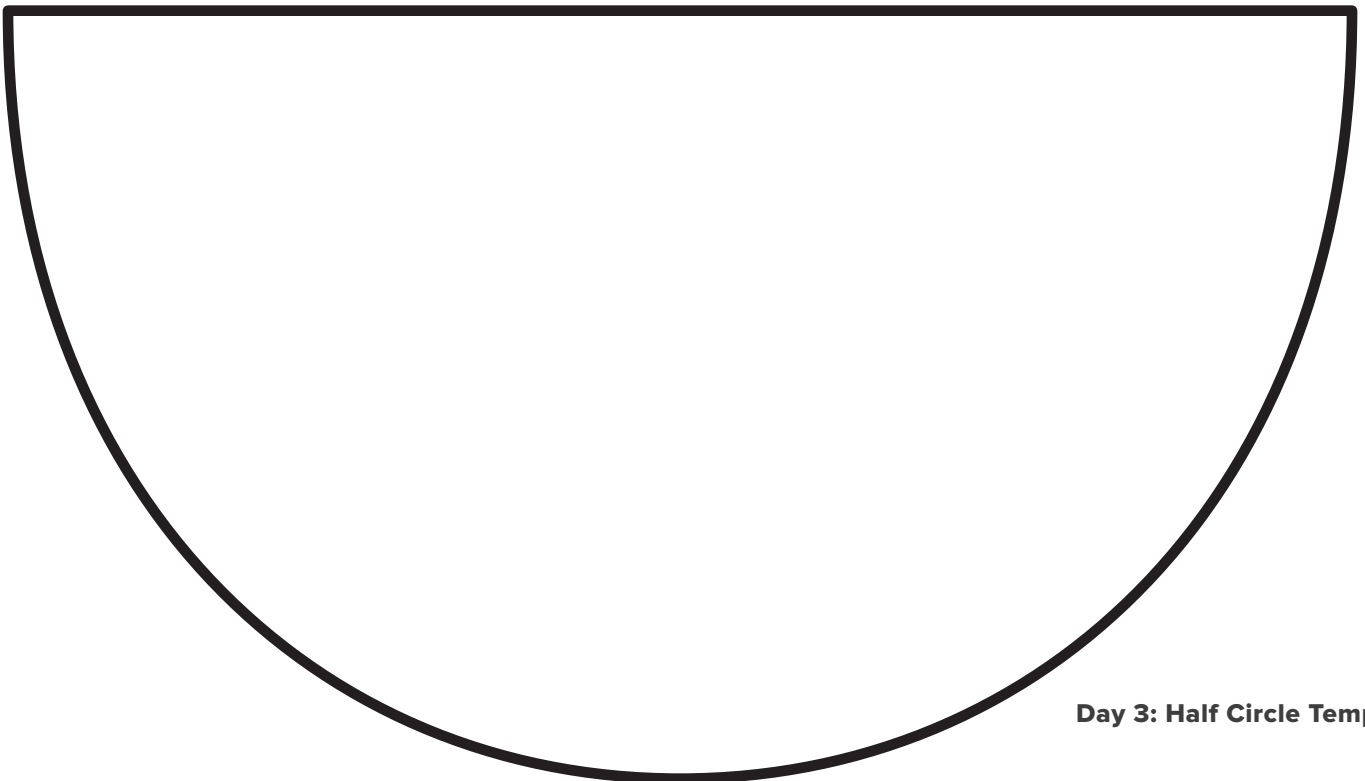

Day 3: Half Circle Template

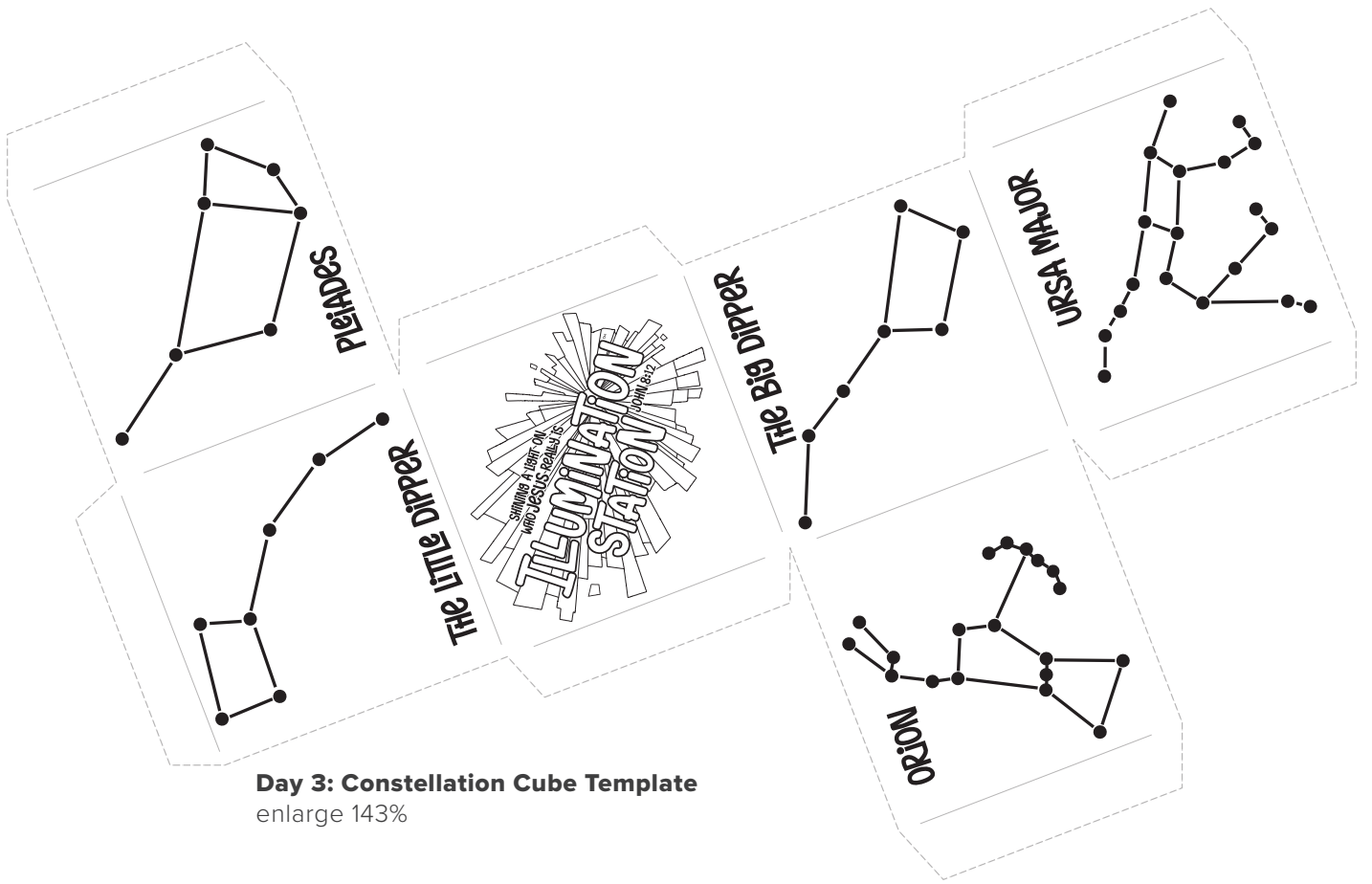

Day 3: Constellation Cube Template
enlarge 143%

**I AM THE LIGHT OF THE WORLD.
JOHN 8:12**

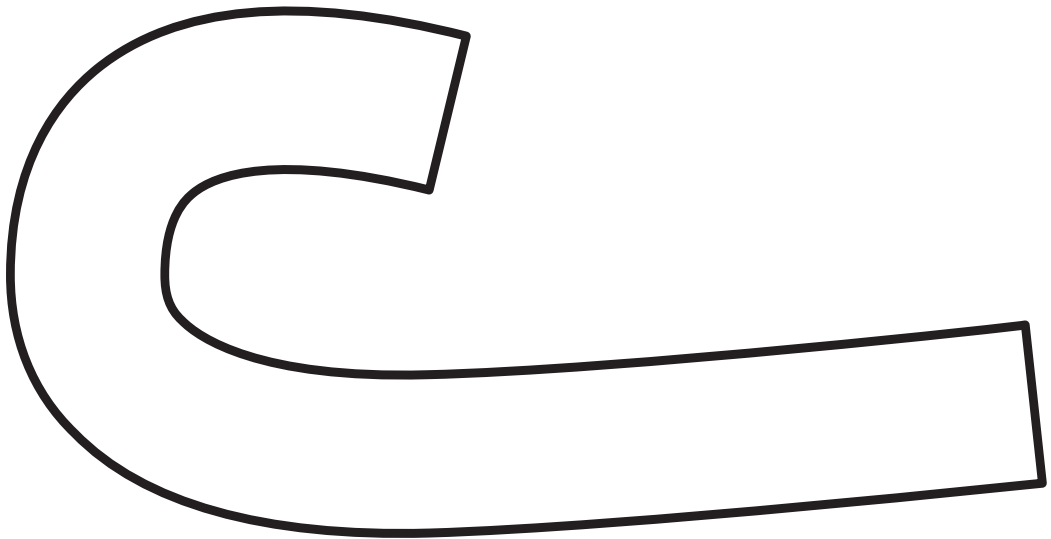

Day 5: Letter J Template
enlarge 142%

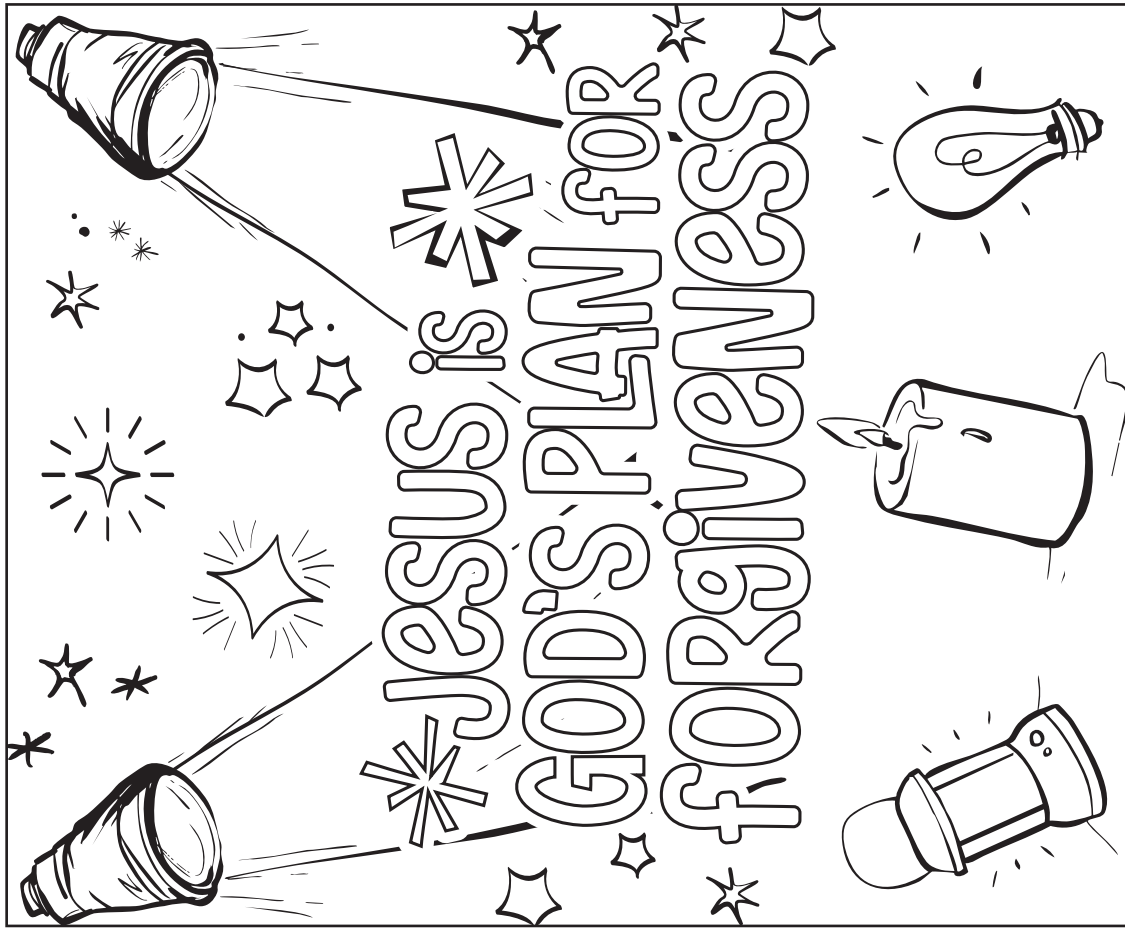

Day 5: Jesus Is God's Plan for Forgiveness
Template



Day 5: Peter Preached about Jesus Template



Jesus Asked Who People Thought He Was



The Baptism of Jesus

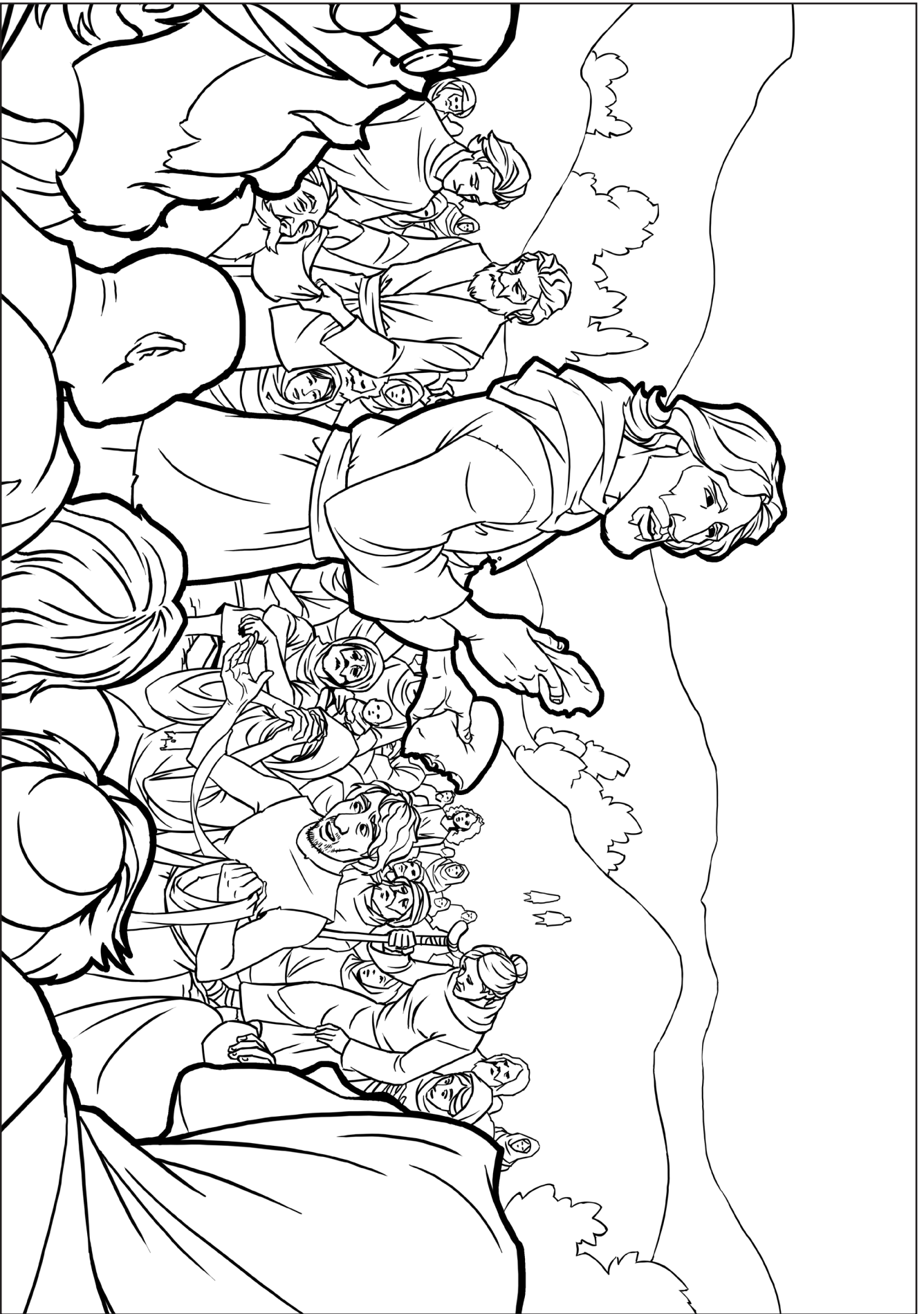

Jesus Performed Miracles



Jesus Died and Rose to Life



Peter Preached About Jesus

JESUS IS THE LIGHT OF THE WORLD

Culture claims to know about Jesus, but many people are in the dark about who He really is. Some might see Jesus as just a person from history or a good man or a good teacher—but He is more than that! Illumination Station VBS will shine a light on the truth of who Jesus really is. Like the disciples, kids will be challenged to answer Jesus' question, "Who do you say that I am?" They will discover it's not a matter of opinion. Jesus is who Scripture says He is—the perfect, proven, and powerful Son of God.