



ILLUMINATION
STATION JOHN 8:12

VBS 2026

* KALEIDOSCOPE *

CRAFTS

Crafts Rotation Leader Guide



SHARING THE GOSPEL WITH KIDS



The word *gospel* means “good news.” It is the message about Christ, the kingdom of God, and salvation. Use the following guide to share the gospel with kids.



GOD RULES. The Bible tells us God created everything, including you and me, and He is in charge of everything. (Genesis 1:1; Revelation 4:11; Colossians 1:16-17)



WE SINNED. Since the time of Adam and Eve, everyone has chosen to disobey God. (Romans 3:23) The Bible calls this sin. Because God is holy, God cannot be around sin. Sin separates us from God and deserves God’s punishment of death. (Romans 6:23)



GOD PROVIDED. God sent His Son, Jesus, the perfect solution to our sin problem, to rescue us from the punishment we deserve. It’s something we, as sinners, could never earn on our own. Jesus alone saves us. (John 3:16; Ephesians 2:8-9)



JESUS GIVES. Jesus lived a perfect life, died on the cross for our sins, and rose again. Because Jesus gave up His life for us, we can be welcomed into God’s family for eternity. This is the best gift ever! (Romans 5:8; 2 Corinthians 5:21; 1 Peter 3:18)



WE RESPOND. We can respond to Jesus. The ABCs of Becoming a Christian is a simple tool that helps us remember how to respond when prompted by the Holy Spirit to receive the gift Jesus offers.

ADMIT to God that you are a sinner. The first people God created chose to sin and disobey God. Ever since then, all people have chosen to sin and disobey. (Romans 3:23) Tell God that you messed up and you are sorry for doing your own thing, and turning away from Him through your thoughts, words, and actions. Repent, turn away from your sin. (Acts 3:19; 1 John 1:9) Repent doesn’t just mean turning from doing bad things to doing good things. It means turning from sin and even from your own good works, and turning to Jesus, trusting only in Him to save you.

BELIEVE that Jesus is God’s Son and receive God’s gift of forgiveness from sin. You must believe that only Jesus can save you, and you cannot save yourself from your sin problem—not even by going to church or reading your Bible. Your faith or your trust is only in Jesus and what He did for you through His life, death, and resurrection. (Acts 16:31; Acts 4:12; John 14:6; Ephesians 2:8-9)

CONFESS your faith in Jesus Christ as Savior and Lord. Tell God and tell others what you believe. If Jesus is your Savior, you are trusting only in Him to save you. Jesus is also Lord, which means He is in charge. You can start following Him and doing what He says in the Bible. You are born again into a new life and look forward to being with God forever. (Romans 10:9-10,13)



If you sense that children are under conviction from the Holy Spirit and would like to respond to the good news, spend some time counseling and praying with them individually. If you sense that a child is not ready to pray and respond in faith and repentance, continue to prayerfully teach him about Christ during the week.



GETTING STARTED

Before arriving, you need to plan out your day and get ready for the kids who will rotate through crafts. Use the following steps for successful preparation.

PREPARE YOUR HEART

- Read the daily Scripture passages from your Bible. Pray that God will speak to you through His Word. (See page 3.)
- Read the teaching materials thoroughly. Highlight key points from the Bible Story Summaries on pages 6, 10, 14, 18, and 22 to gain a deeper understanding of the biblical truths being taught in Bible study.
- Pray for the kids you will teach. Pray for yourself and the other leaders at VBS. Ask people to pray for you as you lead.

PLAN

- Ask your VBS director for the ages and number of kids you will need to prepare for.
- Find out how long you will have with each rotation.
- Select the crafts you would like to make during VBS. Keep in mind how much time you have and the abilities of the age groups you are leading.
- Use the supply lists on pages 4–5 as you plan. Only gather supplies for the crafts you choose to make.
- Make a list of the items your church has, items to collect from church members, and items to buy.
- Copy the templates needed for each craft chosen.
- Prepare a sample of each craft chosen.
- Familiarize yourself with the procedures and what to expect when guiding children.
- Label a box or crate for each day. Place the collected supplies in the appropriate box.

TEACH

- Look for ways to reinforce biblical truths such as using the Craft Connection suggestion for the crafts you have chosen.
- Relax and enjoy the chance to build relationships with the children who will rotate through crafts.
- Be flexible. Adjust your plans to make this the best experience possible for you and the kids you teach.
- Value the process and the fun kids are having over the final result of craft projects.

USE CRAFTS THAT FIT YOUR NEEDS

- The crafts in this guide are designed to reinforce the Bible story, biblical truths, and enhance the overall VBS experience.
- All crafts in this guide are written for and tested with children who have completed grades 1–6.
- Additional ideas for preteens can be found in the *VBS 2026 VBX® Preteen Bible Study Leader Guide* (9798384536949).
- Additional ideas for older preschoolers can be found in the *VBS 2026 3s–Kindergarten Rotation Pack* (9798384537502).
- The following crafts have been made into craft packs to aid you in easy prep:
 - *VBS 2026 Craft Stick Lantern Craft Pack* (9798384539841)
 - *VBS 2026 Baptism Sticker Scene Craft Pack* (9798384539834)
 - *VBS 2026 Illumination Station Shrink Plastic Craft Pack* (9798384539858)
 - *VBS 2026 Constellation Cube Craft Pack* (9798384539872)
 - *VBS 2026 Empty Tomb Silhouette Craft Pack* (9798384539889)
 - *VBS 2026 Scratch Art Frame Craft Pack* (9798384539865)

CONTINUE THE CONNECTION

- Plan to participate in your church's VBS Celebration and other follow-up events.
- Keep the spark alive by looking for ways to stay connected and engaged with the kids you taught.



TABLE OF CONTENTS

ILLUMINATION STATION	3
DECORATING AND SUPPLIES	4
DAY 1: JESUS IS GOD'S PROMISED SON	6
DAY 2: JESUS IS GOD'S PERFECT SON	10
DAY 3: JESUS IS THE POWERFUL SON OF GOD	14
DAY 4: JESUS IS THE PROVEN SON OF GOD	18
DAY 5: JESUS IS GOD'S PLAN FOR FORGIVENESS ...	22
3-5 DAY CRAFT	26
PRETEEN CRAFTS	27
TEMPLATES	28

TEMPLATES

You can find craft templates in the back of this book or you can download full-sized printable versions using the following instructions:

1. Go to my.lifeway.com/redeem and register or log in.
2. Enter this unique code to download all digital resources:
PM99QQNLWDB3
3. Follow the directions to download your resources on any compatible device. Unless otherwise noted, make sure to print at "Actual Size" or 100% to get the intended size.

This code can be redeemed one time.
For customer support, please call 866.627.8553.

© 2025 Lifeway Press®

No part of this work may be reproduced or transmitted in any form or by any means, electronic or mechanical, including photocopying and recording, or by any information storage or retrieval system, except as may be expressly permitted in writing by the publisher. Requests for permission should be addressed in writing to Lifeway Press, 200 Powell Place, Suite 100, Brentwood, TN 37027-7707.

ISBN: 9798384536895
Item: 005853423

Printed in the United States of America
We believe that the Bible has God for its author; salvation for its end; and truth, without any mixture of error, for its matter; and that all Scripture is totally true and trustworthy. To review Lifeway's doctrinal guideline, please visit lifeway.com/doctrinalguideline.

Unless otherwise indicated, all Scripture quotations are taken from the Christian Standard Bible®, Copyright © 2017 by Holman Bible Publishers. Used by permission. Christian Standard Bible® and CSB® are federally registered trademarks of Holman Bible Publishers.

Illumination Station™ and any other trademarks, service marks, logos, and graphics used herein are the trademarks or registered trademarks or service marks of Lifeway. Other trademarks, service marks, graphics, and logos used in connection with this product may be the trademarks of their respective owners. You are granted no right or license with respect to any of the trademarks or service marks mentioned above or any use of such trademarks or service marks except as specifically stated within this product.

Send questions/comments to:
VBS Publishing Team Leader by email to vbs@lifeway.com
or by mail to
VBS Publishing Team Leader,
VBS 2026 Crafts Rotation Leader Guide
200 Powell Place, Suite 100, Brentwood, TN 37027-7707
or make comments on the web at lifeway.com.

PUBLISHING TEAM

Shelly Harris
Publishing Team Leader

Bethany Phillips
Content Editor

Rachel Woodruff
Production Editor

Keith Tyrrell
Graphic Designer

Beth McGill
Production Graphic Designer

Jeremy Carroll
Publishing Manager, VBS, Hyfi, and Kids Discipleship

Chuck Peters
Director, NextGen Ministries

Megan Green
Writer

ILLUMINATION STATION

Culture claims to know about Jesus, but many people are in the dark about who He really is. Some might see Jesus as just a person from history or a good man or a good teacher—but He is more than that! This summer, VBS will shine a light on the truth of who Jesus really is.

Meet us at Illumination Station for the brightest week of the year. Focus on Jesus at Spotlight Bible Study and bask in the colorful glow of sunlight streaming in at Suncatcher Recreation. Twirl in the glittering refracted light of Mirror Ball Music and pass through strands of twinkling lights on the way to Kaleidoscope Crafts. Turn it all the way up for Neon Snacks and bring it all the way down for Glow-in-the-dark Missions. Kids will explore all the ways light brightens, illuminates, reflects, and reveals while discovering that Jesus is the light who brings hope to a dark world! Like the disciples, kids will be challenged to answer Jesus' question, "Who do you say that I am?" They will discover it's not a matter of opinion. Jesus is who Scripture says He is—the perfect, proven, and powerful Son of God.

Light up your summer at Illumination Station and shine a light on Jesus!

VBS Scripture

Jesus spoke to them again: "I am the light of the world. Anyone who follows me will never walk in the darkness but will have the light of life." *John 8:12*

Then spake Jesus again unto them, saying, I am the light of the world: he that followeth me shall not walk in darkness, but shall have the light of life.

John 8:12 (KJV)

VBS Motto

Jesus is the Light of the world.

DAY
1

Day 1: Jesus Is God's Promised Son - Jesus Asked Who People Thought He Was (Matthew 16:13-20)

Jesus asked His disciples who people said that He is and who the disciples said that He is. Simon Peter said Jesus was the Messiah. Jesus said Peter was blessed because God had revealed the truth to him. Jesus said Peter would share the good news about Jesus and start His church.

DAY
2

Day 2: Jesus Is God's Perfect Son - The Baptism of Jesus (Matthew 3:13-17; Mark 1:1-11; John 1:29-34)

God sent John the Baptist to get people ready for Jesus. Jesus told John that He wanted to be baptized because God said it was right so John baptized Jesus. God's voice came from heaven. "This is My Son," the voice said. "I love Him, and I am very pleased with Him!"

DAY
3

Day 3: Jesus Is the Powerful Son of God - Jesus Performed Miracles (Matthew 15:29-39)

Large crowds came and Jesus healed sick people in the crowd. Jesus wanted to provide food. The disciples had 7 loaves of bread and a few small fish. Jesus broke the food into pieces. There was enough for everyone to eat until they were full and there were 7 large baskets of leftovers! Jesus fed 4,000 men plus women and children that day.

DAY
4

Day 4: Jesus Is the Proven Son of God - Jesus Died and Rose to Life (Mark 14:43-16:7)

Jesus was arrested, put on trial, and nailed to a cross. After Jesus died, He was buried in a tomb. Some women went to the tomb. When they got there, they saw that the stone had been rolled away. They went in but did not find Jesus' body. Instead, a man dressed in a white robe told them Jesus is alive!

DAY
5

Day 5: Jesus Is God's Plan for Forgiveness - Peter Preached About Jesus (Acts 2)

Peter told a crowd that God had proven who Jesus was by doing miracles, wonders, and signs through Him. The people were very sorry for their sins. Peter told them to repent—turn from disobeying God to obeying God—and be baptized in the name of Jesus for the forgiveness of their sins. That day about 3,000 people responded to Peter's message, repented, and were baptized.

DECORATING AND SUPPLIES

DECORATING

Use these ideas to create the feel of being at Kaleidoscope Crafts:

- Print and cut out 5 flashlight shapes. Use 5 pieces of poster board in 5 neon colors to draw and cut out beams of light coming from the flashlights and culminating in a large circular pool of light. Write Today's Point for each day on one of the light blobs. Attach each one to the focal wall so that it looks like the flashlight is shining the point onto the wall.
- Create a trail leading into your room using the *VBS 2026 Floor Prints* (9798384538219).
- Hang posters from the *VBS 2026 Visual Pack* (9798384538585) on the walls. Drape *VBS 2026 String Flags* (9798384538226) from the ceiling.
- Use *VBS 2026 Cups* (9798384538059) to store craft supplies. Protect tables with *VBS 2026 Tablecloths* (9798384538189).
- Attach the appropriate *VBS 2026 Rotation Sign* (9798384538615) outside the door.
- See *VBS 2026 Decorating Made Easy* (9798384536987) for additional ideas.

EVERYDAY SUPPLIES

- Markers, permanent markers, colored pencils, and crayons
- Tape (clear and packing)
- Pencils
- Rulers
- Paper towels
- Scissors (adult use and child-safety)
- Glue (Tacky® glue, school glue, glue dots, and glue sticks)
- Newspaper, *VBS 2026 Tablecloths* (9798384538189), or plastic tablecloths
- VBS 2026 Theme Stickers* (9798384538158)
- VBS 2026 Sticky Foam Shapes* (9798384538134)

Day 1

Flashlight Name Search

- Templates
 - "Flashlight Template"
 - "Names of Jesus Template"
- Clear page protectors
- Colorful permanent markers
- Black cardstock
- Paper
- Cardstock

Craft Stick Lantern (Craft Pack)

- Templates
 - "Square Template"
- Jumbo craft sticks (12 per child)
- Parchment paper
- Decorative duct tape
- Cool melt hot glue gun (leader use)
- Dry erase board or poster board
- Battery-powered votive candles (optional)

Light Bulb Melt

- Light-bulb-shaped clear plastic ornaments
- Unwrapped crayons
- Small, hand-held pencil sharpeners (1 per kid, with no reservoir)
- Blow dryers
- Bowls
- Funnels
- Spoons
- Metallic permanent markers (optional)

Day 2

Baptism Scene (Craft Pack)

- Templates
 - "Baptism Scene Template"
- Tempera paint (colors listed on p. 11)
- Paintbrushes
- White cardstock
- Paper plates
- Paint smocks
- Poster board
- Cups of water

Light of the World Tea Light

- Sharp knife/box cutter (adult use)
- White table tennis balls (1 per kid)
- Permanent markers (in multiple colors)
- Fine-point permanent markers (black, optional)
- Rubbing alcohol
- Small spray bottles
- Battery-operated tea lights

Reflection Mirror Ball

- Ball pit balls
- Aluminum foil tape
- String (12 inches per kid)
- Bowls

3-5 Day Craft: DIY Stained Glass

- Templates
 - "Stained-glass Art Templates 1-3"
- 8-by-10 picture frame with plastic insert
- Squeeze bottles
- Black acrylic paint
- Foam bowls
- Spoon
- Funnel
- Watercolors
- Paintbrushes
- Paint cups
- Cool melt hot glue gun (adult use only)



Day 3

“Multiplying” Loaves & Fish

- Templates
 - “Fish Template”
 - “Loaves Template”
- Blue Paper
- Brown Paper
- Paper plates with ridged edges (2 per child)
- Unwrapped brown crayons
- Stapler
- Masking tape (optional)

Light Bulb Moment Key Chain (Craft Pack)

- Template
 - “Small Light Bulb Template”
- Shrink plastic or #6 plastic sheets
- Permanent markers (regular and fine-tip)
- Colored pencils
- Parchment paper
- Toaster oven (adult use only)
- Hole punch
- Key ring and ball chain, or another type of key chain
- Dry erase board or poster board
- Oven mitts
- Sandpaper (if using #6 plastic)

Constellation Cube (Craft Pack)

- Template
 - “Constellation Cube Template”
- 11-by-17 cardstock
- Glow bracelet or small glow stick
- Wood skewers or large push pins
- Silver foil star stickers
- Crystal clear gift wrap tape
- Foam core board
- Ruler or scoring tool

Day 4

Empty Tomb Silhouette (Craft Pack)

- Templates
 - “Empty Tomb Template”
- Black cardstock
- Gel pens
- Cellophane sheets in four different colors
- Contact paper

Mini Lava Lamp

- Plastic test tubes with screw-top lids (1 per kid)
- Cooking oil
- Water
- Fizzy bath tablets
- Knife (adult use only)

Light Bulb String Art

- Templates
 - “Large Light Bulb Template”
- ½-inch insulation foam (one 9-by-7-inch piece per kid)
- Push pins (22 per kid)
- Yellow string (approximately 36 inches per child)
- Permanent markers in several colors

Day 5

Light of the World Candle

- Templates
 - “Candle Template”
- White pillar candle (2.5-by-2.8-inch or similar, 1 per kid)
- White tissue paper
- Waxed paper
- Fine-tipped permanent markers
- Scissors and clean nail scissors
- Blow dryer

Scratch Art Frame (Craft Pack)

- White cardstock frame
- Unwrapped crayons
- Dish soap
- Black paint
- Small foam bowl
- Foam paintbrush
- Skewers or chopsticks
- Blow dryer
- 1-inch self-adhesive magnet pieces
- Craft knife (leader use only)

Dazzling Kaleidoscope

- Paper towel tube (1 per kid)
- Rubber bands (3 per kid)
- Tape
- Clear plastic wrap (5-inch square/child)
- Tracing paper (5-inch square/child)
- Black paper (5-inch square/child)
- Long-reach hole punch (leader use only)
- Mirror paper
- Small translucent beads or multi-colored sequins
- Decorative paper
- Ruler and scoring tool

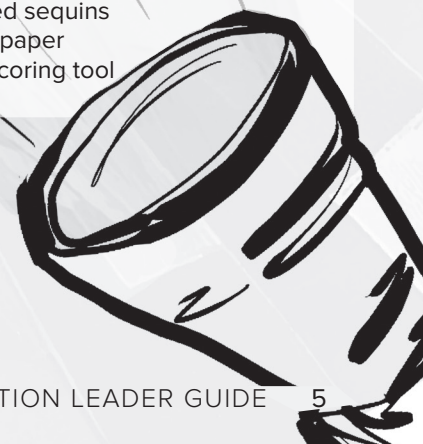

DAY 1

JESUS IS GOD'S PROMISED SON



BIBLE STORY

Jesus Asked Who People Thought He Was
(*Matthew 16:13-20*)

Spotlight Question: Who is Jesus?

Jesus is the Messiah, the promised Son of God.

Today's Point: Jesus is God's promised Son.

THEME VERSE

- Jesus spoke to them again: "I am the light of the world. Anyone who follows me will never walk in the darkness but will have the light of life."
John 8:12
- Then spake Jesus again unto them, saying, I am the light of the world: he that followeth me shall not walk in darkness, but shall have the light of life. *John 8:12 (KJV)*

BONUS VERSE

- You are the Messiah, the Son of the living God.
Matthew 16:16
- Thou art the Christ, the Son of the living God.
Matthew 16:16 (KJV)

BIBLE STORY SUMMARY

Jesus Asked Who People Thought He Was
(*Matthew 16:13-20*)

Jesus asked His disciples who people said that He is. Many people believed Jesus was a prophet. Many thought He was John the Baptist, Elijah, or Jeremiah come back to life. Jesus asked who the disciples said that He is. Simon Peter said Jesus was the Messiah, the Son of the living God. Jesus said Peter was blessed because God had revealed the truth to him about who Jesus is. Jesus said Peter would share the good news about Jesus and start His church.

FLASHLIGHT NAME SEARCH

CRAFT CONNECTION

Say: “How do we identify who someone is? Most often we use someone’s name. Jesus has many names: Son of God, Prince of Peace, Wonderful Counselor, and more! Each of these names help us understand something important about Him. Which names did Peter use to show He knew who Jesus really is in today’s story?”
(*Messiah, Son of the living God*)

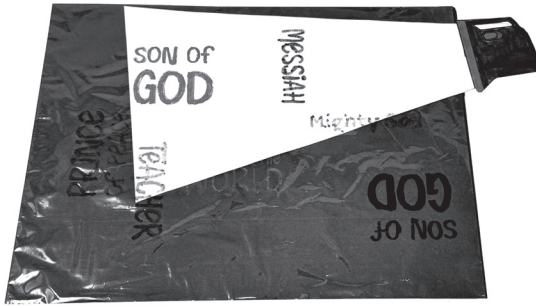

GATHER

- ❑ Templates
 - ❑ “Flashlight Template” (p. 28)
 - ❑ “Names of Jesus Template” (p. 28)
- ❑ Clear page protectors
- ❑ Colorful permanent markers
- ❑ Scissors
- ❑ Black cardstock
- ❑ Paper
- ❑ Cardstock (black and white)

LEADER PREP

- ❑ Print a “Flashlight Template” for each kid on white cardstock.
- ❑ Print a “Names of Jesus Template” for each kid on regular paper.
- ❑ Slide a “Names of Jesus Template” into a page protector for each kid. Slide a piece of black cardstock behind each template.

TIP FROM OUR TESTER

The most effective color combination at hiding the words was yellow marker and yellow cardstock paper, with a white light beam though this is less like shining a light in a dark space!

Kids Said ...

“This is super fun.”
“Nicodemus called Jesus, ‘Teacher.’”
“I like coloring.”

ASSEMBLE

Step 1: Direct each child to color a “Flashlight Template,” making the beam a light color, such as yellow, and then cut it out. If time is short, leave the beam white.

Step 2: Use colorful permanent markers to trace the “Names of Jesus Template” onto the clear page protector. Avoid using the same color as your flashlight beam.

Step 3: After tracing is finished, remove the “Names of Jesus Template,” leaving behind the sheet of black cardstock.

Step 4: Let children find different names of Jesus by inserting their flashlight into the page protect and “shining” it on the names they traced.

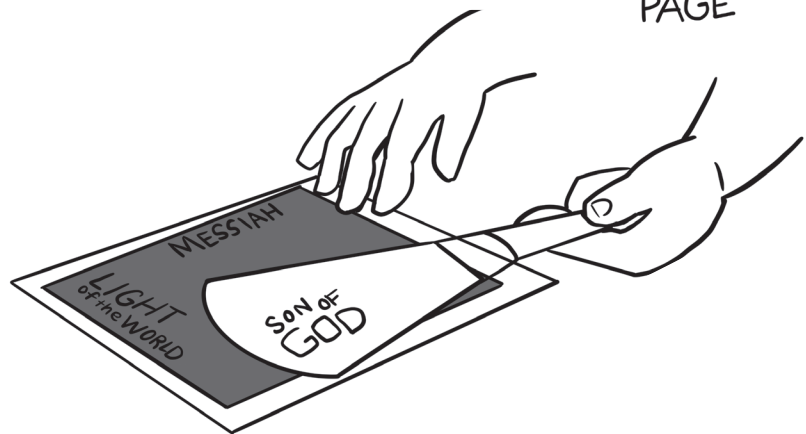
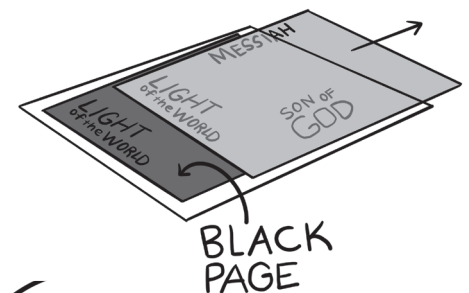
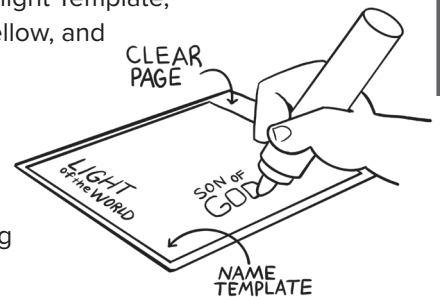

CRAFT PACK

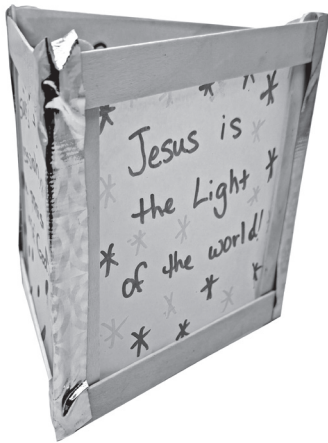

CRAFT STICK LANTERN

CRAFT CONNECTION

Say: “The designs on the sides of your lanterns are so pretty, but they are even more beautiful once a light is added inside! Then they shine brilliantly! Our motto reminds us that ‘Jesus is the Light of the world.’ The Bible describes sin as being like darkness. It is hard for us to see the right thing to do because of our sin. But Jesus came to bring light to that darkness. When we repent of our sins, receive His gift of forgiveness, and follow Him, our lives are lit up by His light, just like your lanterns.”

GATHER

- Templates
 - “Square Template” (p. 29)
- Jumbo craft sticks (12 per child)
- Parchment paper
- Decorative duct tape
- Cool melt hot glue gun (leader use)
- Clear tape
- Scissors
- Markers
- Glue sticks
- Dry erase board or poster board
- Battery-powered votive candles (optional)

LEADER PREP:

- Cut parchment paper into 5½-by-5½-inch squares (each child will need 3 squares).
- On a dry erase board or piece of poster board, write the VBS theme verse and Today’s Point from the first page of this session, along with the VBS motto (*Jesus is the Light of the world*).
- Use a hot glue gun to make square frames out of 4 craft sticks each, 3 frames for each kid. Use the “Square Template” to help make each square even.

ALTERNATE OPTION

Materials for a similar craft can be found in the *VBS 2026 Craft Stick Lantern Craft Pack* (9798384539841).

NOTE: The craft pack version of this craft does not include battery-powered candles.

Kids Said ...

“I’ll put it on my shelf for a night light.” “I like this one.”

ASSEMBLE

Step 1: Using glue sticks, secure a piece of parchment paper to the back of each square frame. Reinforce anywhere that needs it with clear tape.

Step 2: Flip frames over so you are looking through them at blank parchment paper. On the first parchment paper square, write the motto. On the second parchment paper square, write the theme verse. On the third parchment paper square, write Today’s Point. Decorate squares as desired.

Step 4: Lay craft stick frames side by side, but not touching, and connect the edges next to each other with strips of duct tape cut in half.

Step 5: Stand the frames up and use duct tape to cover the final seam, creating a three-dimensional triangle.

Step 6: If desired, insert a battery-powered votive inside the lantern to light up the designs.

Leader Tips:

- Provide younger kids parchment paper templates to trace. Allow them to write the motto on all three sides for simplicity.

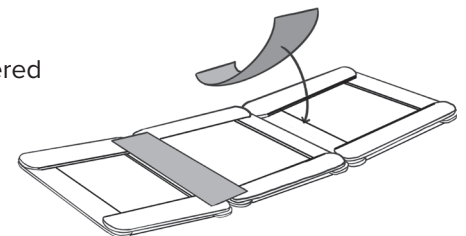
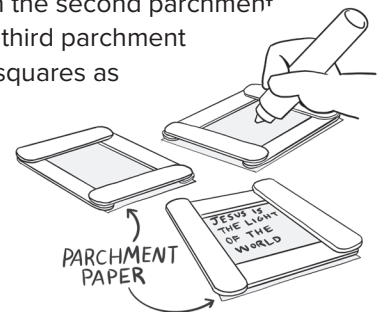

LIGHT BULB MELT

CRAFT CONNECTION

Ask the kids to guess what they think their completed ornament will look like. Explain that even as they fill the inside with their chosen colors, it's hard to predict at first how the heat will transform the inside of the ornament. Say: "When Jesus first called Peter to follow Him, Peter was a fisherman. But in today's story Jesus told Peter that Peter would share the good news about Jesus and start His church. When Peter followed Jesus, Jesus transformed Peter, not just by giving him a new job but by forgiving Peter for his sins. Jesus changes us, too, when we follow Him and repent of our sins."



FAVORITE OF THE DAY

GATHER

- Light-bulb-shaped clear plastic ornaments
- Unwrapped crayons
- Small, hand-held pencil sharpeners (1 per kid, with no reservoir)
- Blow dryers
- Bowls
- Funnels
- Spoons
- Metallic permanent markers (optional)

LEADER PREP:

- For younger kids, create crayon shavings ahead of time.

LEADER TIPS

- Emphasize that fewer colors will create a better result. Guide kids to choose colors that will mix well such as red, orange, and yellow or green, blue, and purple. Too many colors will melt into brown.
- Older children may be able to use the blow dryer with supervision. Younger children will need an adult to complete step 4 for them.

ASSEMBLE

Step 1: Allow each child to choose 3–4 different colored crayons.

Step 2: Using a pencil sharpener over a bowl, guide kids to create crayon shavings of their chosen colors, all mixed together.

Step 3: Pour the crayon shavings into the ornament using a spoon and funnel.

Step 4: Using a blow dryer, gently rotate the ornament to melt the crayon shavings inside.

Step 5: Once the bulb is cool, allow older kids to write *Jesus is God's promised Son* on the bulb in metallic permanent marker if desired.

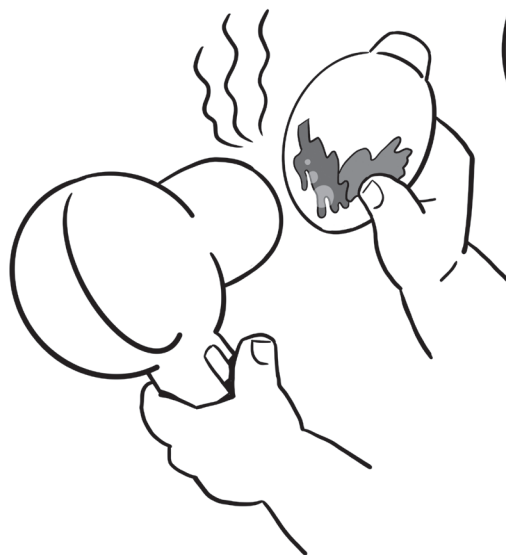

Kids Said ...
"I've got an idea."
(3rd grade boy with
light bulb over his head)
"This is awesome!"

DAY 2

JESUS IS GOD'S PERFECT SON



BIBLE STORY

The Baptism of Jesus (*Matthew 3:13-17; Mark 1:1-11; John 1:29-34*)

Spotlight Question: Was Jesus just an ordinary man?

Jesus is the perfect Son of God who came to be the Savior of the world.

Today's Point: Jesus is God's perfect Son.

THEME VERSE

- Jesus spoke to them again: "I am the light of the world. Anyone who follows me will never walk in the darkness but will have the light of life."
John 8:12
- Then spake Jesus again unto them, saying, I am the light of the world: he that followeth me shall not walk in darkness, but shall have the light of life. *John 8:12 (KJV)*

BONUS VERSE

- A voice came from heaven: "You are my beloved Son; with you I am well-pleased." *Mark 1:11*
- There came a voice from heaven, saying, Thou art my beloved Son, in whom I am well pleased.
Mark 1:11 (KJV)

BIBLE STORY SUMMARY

The Baptism of Jesus
(*Matthew 3:13-17; Mark 1:1-11; John 1:29-34*)

God sent John the Baptist to get people ready for Jesus. People heard John's message and started to repent of their sin. They wanted to stop disobeying God, so they asked God for forgiveness. Then John baptized them. He lowered them in the water and brought them back up to show that they had asked God for forgiveness. John preached that Jesus was coming. Jesus went to see John the Baptist at the Jordan River. Jesus told John that He wanted to be baptized because God said it was right, so John baptized Jesus. God's voice came from heaven. "This is My Son," the voice said. "I love Him, and I am very pleased with Him!"

CRAFT PACK



BAPTISM SCENE

CRAFT CONNECTION

Ask: “Why was John baptizing people?” (*He was helping them prepare for Jesus’ arrival.*) **Say:** “Jesus asked John to baptize Him, too. Even though Jesus was baptized like other people, He was not just an ordinary man. He is the perfect Son of God who came to be the Savior of the world.”

GATHER

- Templates
 - “Baptism Scene Template” (p. 29)
- Tempera paint in the colors listed below
- Paintbrushes
- White cardstock
- Paper towels
- Paper plates
- Paint smocks
- Poster board
- Cups of water

LEADER PREP

- Print a “Baptism Scene Template” on white cardstock for each child.
- Place a dollop of each color of paint on a paper plate for each child.
- Write the following key on poster board and paint swatches next to each number:
 - 1—brown
 - 2—tan
 - 3—yellow
 - 4—orange
 - 5—gray
 - 6—green
 - 7—red
 - 8—light blue
 - 9—dark blue

LEADER TIP

Markers/crayons can be substituted for paint.

ALTERNATE OPTION

Materials for a similar craft can be found in the *VBS 2026 Baptism Sticker Scene Craft Pack* (9798384539834).

Kids Said ...

“Oh! We’re painting!”
“This is fun.”

Step 1: Distribute paint smocks and paintbrushes. Give each child a “Baptism Scene Template.”

Step 2: Distribute paper plates with tempera paint.

Step 3: Instruct kids to paint the numbers with their corresponding colors, using cups of water and paper towels to clean brushes between colors.

Note: Some formulations of tempera paint contain eggs. Check your packaging and post an allergy alert if necessary.

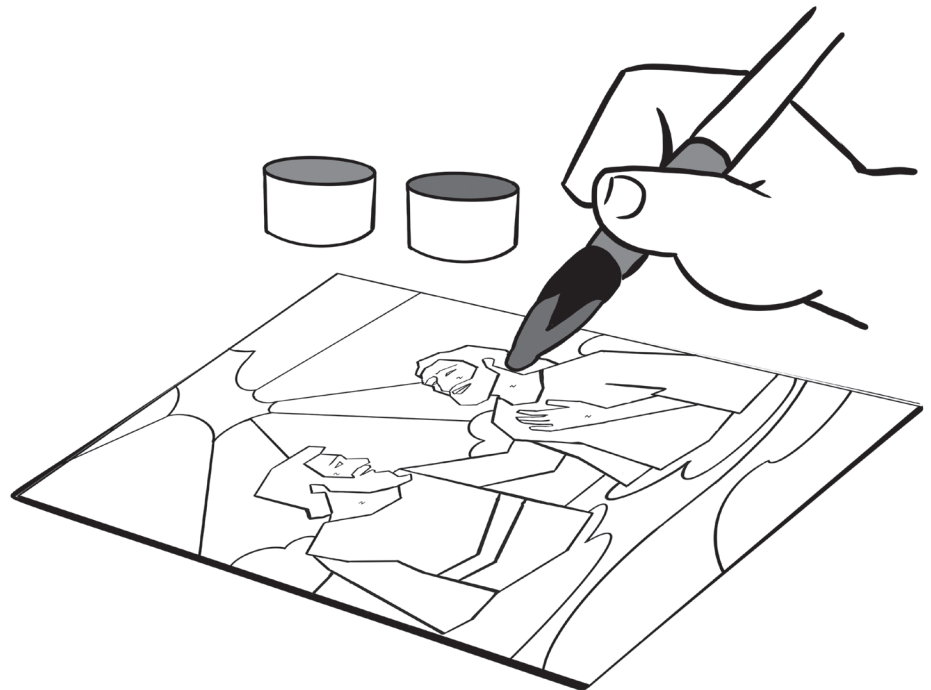

LIGHT OF THE WORLD TEA LIGHT

CRAFT CONNECTION

Say: “Your table tennis balls kind of remind me of planets! They may look a lot different than the Earth, but they can remind you that Jesus is the perfect Son of God who came to be the Savior of the world.”



GATHER

- ❑ Sharp knife/box cutter (adult use)
- ❑ White table tennis balls (1 per kid)
- ❑ Permanent markers (in multiple colors)
- ❑ Fine-point permanent markers (black, optional)
- ❑ Rubbing alcohol
- ❑ Small spray bottles
- ❑ Battery-operated tea lights
- ❑ Paper towels

LEADER PREP

- ❑ Use the knife to cut a small X or hole in the bottom of each table tennis ball.
- ❑ Fill the spray bottles with rubbing alcohol.

LEADER TIPS

- Call time so kids will stop coloring and spray, allowing plenty of time for lights to dry before writing on the base.
- Hand sanitizer will help clean marker-stained hands.
- Remind kids that the colors will mix and run. Caution kids not to spray too close to the light or to use too much alcohol. It's best to spray a little and let it mix, then add more as needed.

NOTE FROM OUR TESTER

Some brands are softer and require twisting the craft knife. Others are harder and may create sharp edges. Consider placing the ball on the light before the session if you use the harder type.

Kids Said ...

“Coolest thing ever!” “I would use it as a night-light.”
“Nothing could beat this.”

ASSEMBLE

Step 1: Insert the tea light “flame” in the X or hole on the bottom of the table tennis ball.

Step 2: Set the light on a paper towel.

Step 3: Use permanent markers to apply color to the ball and light base.

Step 4: Spray lightly with alcohol to make the colors blend.

Step 5: Allow the light to dry.

Step 6: If you have time, allow older kids to use fine-point permanent markers to write *Jesus is my light* on the base of the light.

Step 7: Pull the tab on the bottom of the light to activate the battery if the light is new. Turn the light on and admire your tea light.

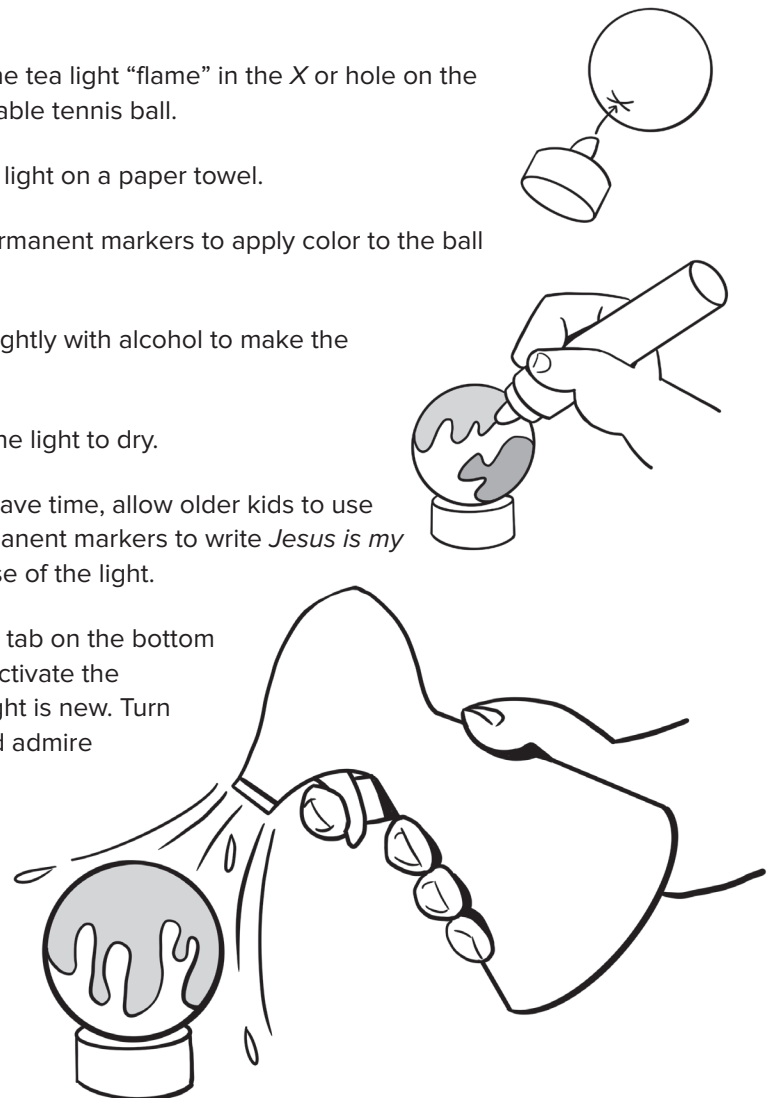

REFLECTION MIRROR BALL

CRAFT CONNECTION

Say: “A mirror ball can’t make its own light. Instead, it reflects the light that is around it. In the same way, when you choose to repent from your sins and follow Jesus, He asks you to follow His example of baptism to show an outward reflection of the change that He has made in your life. We cannot change ourselves or take away our sins. But Jesus can! He can make those changes because He is not an ordinary man; He is the perfect Son of God.”

FAVORITE OF THE DAY

GATHER

- ❑ Ball pit balls (1 or more per kid)
- ❑ Aluminum foil tape
- ❑ String (12 inches per kid)
- ❑ Bowls
- ❑ Scissors (adult use)

LEADER PREP

- ❑ Cut 1 or 2-inch squares of aluminum foil tape (and the attached backing) and place in bowls

LEADER TIPS

- Consider drawing lines across the ball before beginning in order to more easily line up the “mirror” rows.
- If your time is short, larger pieces of tape will make the craft go quicker.

NOTES FROM OUR TESTER

- Caution kids not to overlap the tape too much.
- This was easy to prep and the kids loved it!

ASSEMBLE

Step 1: Beginning near the bottom of the ball, stick a line of aluminum foil tape squares in a line around the ball.

Step 2: Begin a new row of foil tape squares just above the first row with the bottom of each piece slightly overlapping the top of the piece beneath. Show kids how to place squares so that they are staggered between the pieces on the previous row.

Step 3: Continue adding rows upward along the ball until the entire surface is covered. When you reach the top, fold the piece of string in half and tape both ends to the ball to use as a hanger.

Step 4: Return to the bottom of the ball and cover any empty space there.

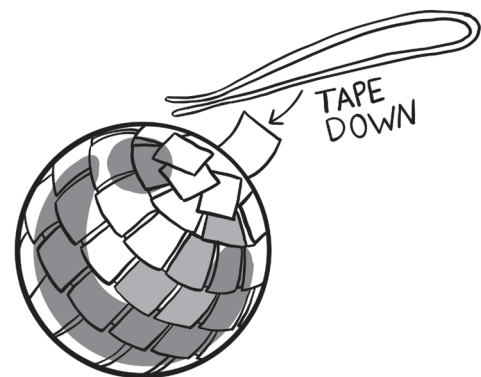
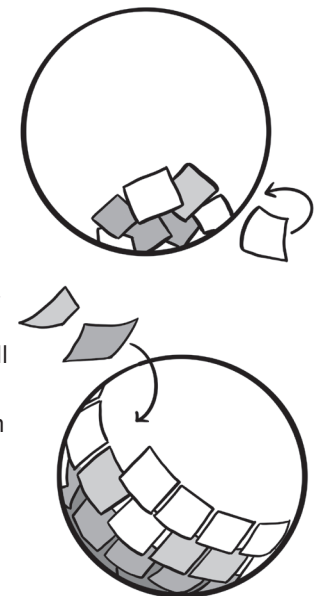

Kids Said ...

“I’m going to hang it in my room.” “Reflect on Jesus!”

DAY 3

JESUS IS THE POWERFUL SON OF GOD

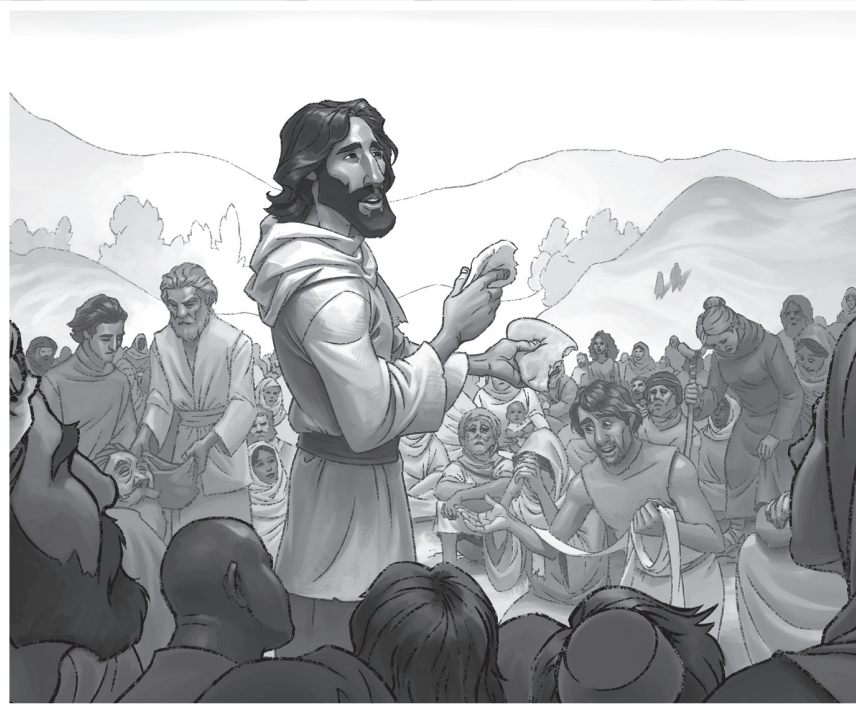

BIBLE STORY

Jesus Performed Miracles (*Matthew 15:29-39*)

Spotlight Question: Was Jesus just a teacher? Everything Jesus said and did showed that He is the powerful Son of God.

Today's Point: Jesus is the powerful Son of God.

THEME VERSE

- Jesus spoke to them again: "I am the light of the world. Anyone who follows me will never walk in the darkness but will have the light of life."
John 8:12
- Then spake Jesus again unto them, saying, I am the light of the world: he that followeth me shall not walk in darkness, but shall have the light of life. *John 8:12 (KJV)*

BONUS VERSE

- Jesus came near and said to them, "All authority has been given to me in heaven and on earth."
Matthew 28:18
- Jesus came and spake unto them, saying, All power is given unto me in heaven and in earth.
Matthew 28:18 (KJV)

BIBLE STORY SUMMARY

Jesus Performed Miracles
(*Matthew 15:29-39*)

One day Jesus went up a mountain. Large crowds of people came including people who were sick. Jesus healed them. He could do this because He is God's Son. Jesus wanted to provide food for the people but the disciples didn't know where they could get enough. Jesus asked how much food they had with them. They had 7 loaves of bread and a few small fish. Jesus thanked God for the food and began to break it into pieces. There was enough for everyone to eat until they were full and there were 7 large baskets of leftovers! Jesus fed 4,000 men plus women and children that day.

"MULTIPLYING" LOAVES & FISH

CRAFT CONNECTION

Say: "In today's Bible story, Jesus didn't say that He was powerful; He showed that He is powerful. The miracles He performed could not have been done by a teacher. They were only possible because He is the powerful Son of God." Show kids your sample craft. Allow a volunteer to unfold and read the loaves. Mention that this is a question they may have asked during Bible study (*Was Jesus just a teacher?*) and that a short version of the answer is on the fish. Allow another volunteer to unfold and read the fish (*Jesus is the powerful Son of God.*) Explain that when kids take their bread and fish out and "multiply them," it's not because they have any special power. But it can be a reminder that Jesus has power because He is God's Son!



GATHER

- Templates
 - "Fish Template" (p. 30)
 - "Loaves Template" (p. 30)
- Blue Paper
- Brown Paper
- Paper plates with ridged edges (2 per child)
- Scissors
- Unwrapped brown crayons
- Stapler
- Masking tape (optional)

LEADER PREP

- Copy the "Fish Template" onto blue paper, one set per kid.
- Copy the "Loaves Template" onto brown paper, one set per kid.

LEADER TIPS

- Demonstrate folding and cutting for kids.
- Mark cutting lines on the plates for younger children.

ASSEMBLE

Step 1: Fold both paper plates in half. In the center of the plate, cut in along the fold to the ridged edge of the plate. Then unfold the plate and cut out half of the middle of the plate from inside the ridged edges. Remove this section. Repeat for the other plate.

Step 2: Using the sides of your crayons, color the back side of both paper plates to look like a woven basket.

Step 3: Line up the openings (handles) in the paper plates and staple the plates together around the edges, including the handles, (with the colored side facing out) to create your basket. Help younger kids cover the staples with masking tape to protect them from getting poked.

Step 4: Cut the fish out around the outside edges, being careful to leave the edges between the fish intact. Older kids may want to cut out the tails as well. Using an accordion fold, (folding one fish toward the front and the next toward the back) fold the fish until they resemble a stack. Repeat the cutting and folding for the brown loaves paper.

Step 5: Allow kids to play with their bread and fish, folding, unfolding, and reading them to each other. Guide them tuck the bread and fish into their baskets to take home.

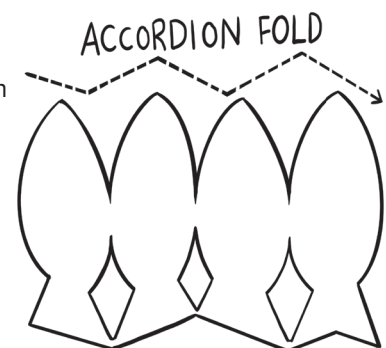
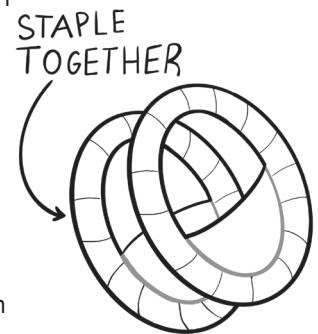
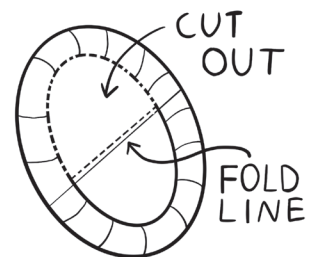
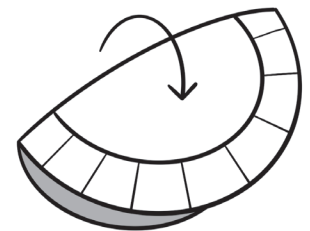

Kids Said ...
"We can act out the loaves and fishes story." "I'm going to hang it on my door."

CRAFT PACK



FAVORITE OF THE DAY

LIGHT BULB MOMENT KEY CHAIN

CRAFT CONNECTION

Ask kids if they have ever heard the phrase “light bulb moment.” Explain that a “light bulb moment” is when someone understands something for the very first time. It is like a light bulb is turned on in a dark room and a person can see or understand something all of a sudden. Ask: “Do you think anyone who saw Jesus heal people or multiply the bread and fish had a light bulb moment that day?” Say: “I hope you will have a light bulb moment at VBS where you learn something new about Jesus and His love for you.”

GATHER

- Template
 - “Small Light Bulb Template” (p. 29)
- Shrink plastic or #6 plastic sheets
- Permanent markers (regular and fine-tip for smaller details)
- Colored pencils
- Scissors
- Parchment paper
- Toaster oven (adult use only)
- Hole punch
- Key ring and ball chain, or another type of key chain
- Dry erase board or poster board
- Oven mitts
- Sandpaper (if using #6 plastic)

LEADER PREP

- Print a template for each child.
- Cut a 4.5-by-3.5-inch rectangle of shrink plastic for each child.
- Write *Jesus is the Light of the world* or *Jesus is my Light* on the dry erase board or poster board.
- If you are using #6 plastic, sand one side of the plastic.

ALTERNATE OPTION

Materials for a similar craft can be found in the *VBS 2026 Illumination Station Shrink Plastic Craft Pack* (9798384539858). See left-hand image above.

LEADER TIP

Staple removers work well to open key chain rings.

Kids Said ...

“I’ll put this on my bag and tell others about Jesus.” “This is epic!”

ASSEMBLE

Step 1: Use permanent markers to trace the template onto a sheet of shrink plastic or any #6 plastic. Color the entire shape with colored pencils on the “rough” side.

Step 2: Write the motto (*Jesus is the Light of the world*) or the words “Jesus is my Light” inside the light bulb. Cut out the shape, leaving a border. Punch a hole in one end of the light bulb, as marked, before you shrink it.

Step 3: Put the light bulbs on a sheet of parchment paper and bake them in a toaster oven following the directions on your shrink plastic. The plastic will shrink up in only 2–3 minutes, so watch them closely! (If you are recycling #6 plastic from plastic containers, shrink for 2–3 minutes at 350 degrees.)

Leader Tip: Consider assigning one adult to run a “toaster oven station.” Kids can bring their finished craft to the station, and a volunteer will write each name on the parchment paper next to the craft. When there are enough crafts to fill the tray, run the oven while continuing to place finished crafts on additional pieces of parchment paper.

Step 4: After the light bulbs have cooled, attach a chain and key ring through the hole punch.

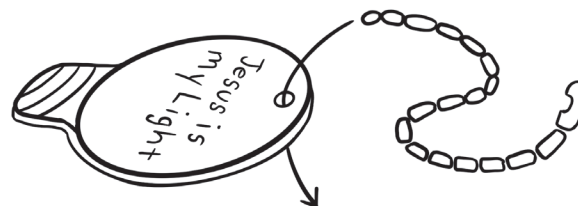
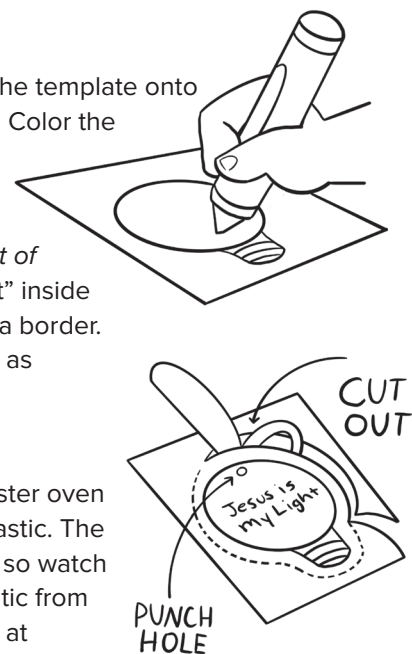

CRAFT PACK



CONSTELLATION CUBE

CRAFT CONNECTION

Say: “Today you heard about several ways Jesus showed His power. But we get to see Jesus’ power on display every single night as the sky lights up with His brilliantly designed creation.” Explain that our minds kind of draw lines between the stars to show us shapes, like a dot-to-dot, and that these are called constellations. Open your Bible and read Job 38:31-32. Say: “These verses talk about some of the constellations we see on this craft and how God controls them. Remember, Jesus is the powerful Son of God!”

GATHER

- Template
 - “Constellation Cube Template” (p. 31)
- 11-by-17 cardstock
- Glow bracelet or small glow stick
- Wood skewers or large push pins
- Silver foil star stickers
- Crystal clear gift wrap tape
- Scissors
- Foam core board
- Ruler or scoring tool

LEADER PREP

- Print one “Constellation Cube Template” for each child on 11-by-17 cardstock.
- Cut out and score each cube on the fold lines for kids.
- Tape each “Constellation Cube Template” onto a piece of foam board.

ALTERNATE OPTION

Materials for a similar craft can be found in the *VBS 2026 Constellation Cube Craft Pack* (9798384539872).

NOTE: The craft pack version of this craft does not include glow sticks.

Kids Said ...

“Punching holes is fun.”
“I’ll put this in my room.”

ASSEMBLE

Step 1: Use a push pin or skewer to punch the holes for each star of the different constellations on the template. Remove the template from the foam board.

Step 2: Fold the template along the dotted lines to form the cube shape. Tape most edges, leaving one side open. Kids may need extra help with this step. Use tape loops to tape the two biggest tabs inside the cube down to the side with no holes.

Step 3: Snap/activate a glow bracelet or stick and put it inside the cube.

Step 4: Tape the final seam on the cube to seal it shut. Use a small piece of tape so you can peel it up later and replace the glow stick.

Step 5: Decorate the cube with star stickers, making sure not to cover any of the holes.

LEADER TIPS

- Consider printing white constellations on black cardstock to make this look more like the night sky. This option is only supported by some printers.
- Alternatively, you may wish to staple the template to black cardstock before taping it down so that when you punch the holes on the template it will punch through the black cardstock. Use the black paper as your final version, labeling and connecting constellations with a white metallic pen.
- You will need a nearly dark room to really see the glow stick light behind the stars. For accountability and safety, always leave your room door open, or if the door has a window, keep it uncovered. Do not darken your room so much that you cannot supervise kids.

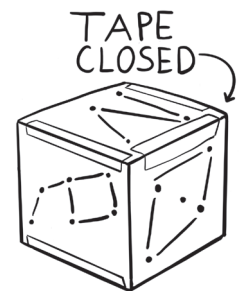
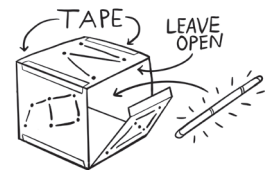
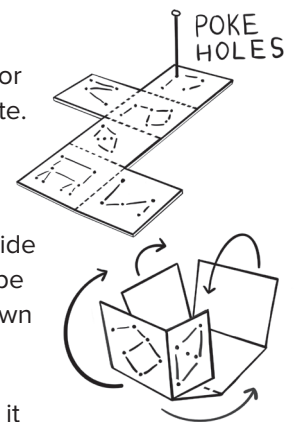

DAY 4

JESUS IS THE PROVEN SON OF GOD

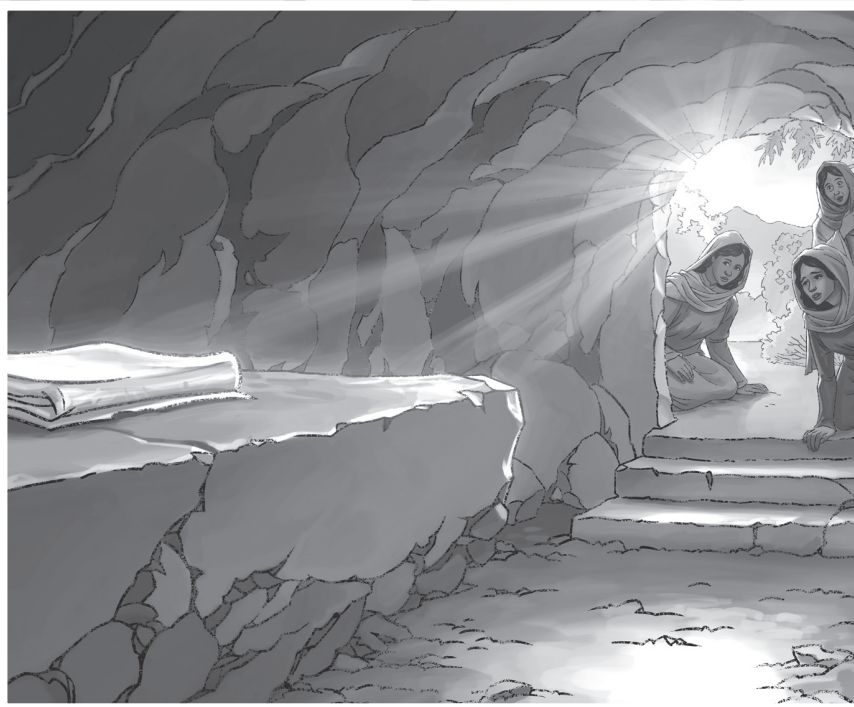

BIBLE STORY

Jesus Died and Rose to Life (*Mark 14:43–16:7*)

Spotlight Question: Was Jesus just someone who lived a long time ago?

Jesus lived, died, and rose to life again to be our Savior, now and forever.

Today's Point: Jesus is the proven Son of God.

THEME VERSE

- Jesus spoke to them again: "I am the light of the world. Anyone who follows me will never walk in the darkness but will have the light of life."
John 8:12
- Then spake Jesus again unto them, saying, I am the light of the world: he that followeth me shall not walk in darkness, but shall have the light of life. *John 8:12 (KJV)*

BONUS VERSE

- When the centurion ... saw the way he breathed his last, he said, "Truly this man was the Son of God!" *Mark 15:39*
- When the centurion ... saw that he so cried out, and gave up the ghost, he said, Truly this man was the Son of God. *Mark 15:39 (KJV)*

BIBLE STORY SUMMARY

Jesus Died and Rose to Life
(*Mark 14:43–16:7*)

The religious leaders did not like Jesus because of the things He was doing and teaching. Jesus taught that He was God's Son, so they wanted to stop Him. Jesus was arrested, put on trial, and nailed to a cross. When Jesus died, a Roman army officer who had been watching Jesus said, "This man really was God's Son!" After Jesus died, He was buried in a tomb. Some women went to the tomb. When they got there, they saw that the stone had been rolled away. They went in but did not find Jesus' body. Instead, a man dressed in a white robe told them Jesus is alive!

CRAFT PACK



FAVORITE OF THE DAY

EMPTY TOMB SILHOUETTE

CRAFT CONNECTION

Show kids your sample craft and ask them if they know what the item in the center is. Say: "When Jesus died, He was buried in a cave with a large rock rolled over the opening. But Jesus didn't stay dead! Jesus' empty tomb reminds us that He was not just someone who lived a long time ago. Jesus lived and died, but then He rose to life again to be our Savior, now and forever. Jesus died to take the punishment for our sins so we can have a relationship with God."

GATHER

- Templates
 - "Empty Tomb Template" (p. 30)
- Black cardstock
- Permanent markers
- Gel pens
- Cellophane sheets in four different colors
- Contact paper
- Scissors

LEADER PREP

- Print an "Empty Tomb Template" for each child.
- Cut two 6-by-6-inch squares of contact paper per kid.
- Cut cellophane sheets into smaller pieces appropriate for the age of the children crafting. For younger kids, consider four 3-by-3-inch squares, one of each color, that will quickly cover the contact paper. For older kids, cut into smaller random shapes so kids can create their own designs.

ALTERNATE OPTION

Materials for a similar craft can be found in the *VBS 2026 Empty Tomb Silhouette Craft Pack* (9798384539889).

LEADER TIPS

- Consider stapling the "Empty Tomb Template" to black cardstock before cutting it out. This way kids only have to cut the shape out once.
- Cut pieces of cellophane smaller to increase the time or larger to shorten the time.

ASSEMBLE

Step 1: Guide kids to cut out the empty tomb silhouette from their template and trace it on a piece of black cardstock using a gel pen. Cut out the black silhouette.

Step 2: Peel the backing off one piece of contact paper and lay it on the table, sticky side up. Place the silhouette in the center of the contact paper.

Step 3: Use the cellophane shapes to cover the contact paper, creating a stained-glass effect.

Step 4: Peel the backing off a second piece of contact paper and place it on the first piece, sticky side down. This will seal the craft together. Trim the edges as needed. Write *Jesus Is Alive* in permanent marker on the outside of the craft.

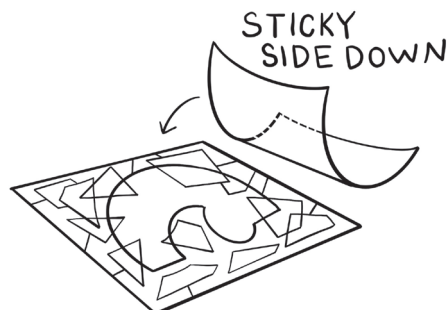
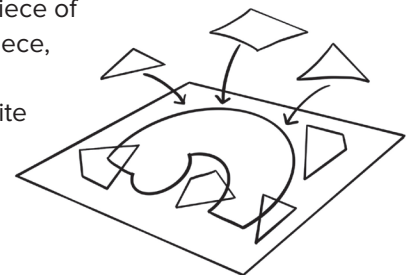
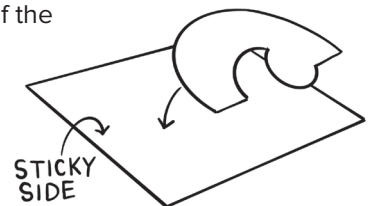
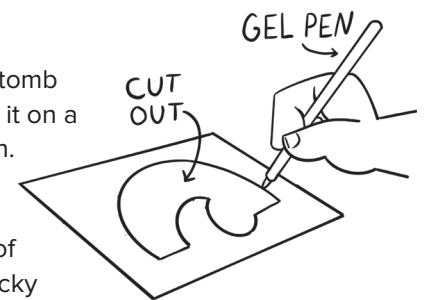

Kids Said ...

"I'll hang it up." "This is pretty."

MINI LAVA LAMP

CRAFT CONNECTION

Say: “When the tablet first drops into the oil, it looks as if nothing will happen. I’m sure the disciples felt the same way when Jesus died. They were surprised and amazed when they discovered that Jesus is alive! The fizzy tablet’s reaction to water is a surprise, but it isn’t a miracle. Jesus rose from the dead because He is God’s Son. Only God has the power to raise someone from the dead.”



FAVORITE OF THE DAY

GATHER

- Plastic test tubes with screw-top lids (1 per kid)
- Cooking oil
- Water
- Fizzy bath tablets
- Knife (adult use only)

LEADER PREP

- Be sure the fizzy bath tablets fit into the test tube openings. If not, use a knife to cut them into pieces, one piece per kid.

NOTES FROM OUR TESTER

- If you can find them, this works best with plastic tubes that are flat on both ends such as party favor containers. Just make sure lids seal well!
- Kids would have happily played with this longer.

ASSEMBLE

Step 1: Fill the test tube halfway with cooking oil.

Step 2: Drop in a fizzy bath tablet.

Step 3: Once the tablet is at the bottom of the test tube, add water to the test tube leaving a small amount of empty space at the top.

Step 4: After the bath tablet finishes fizzing, place the screw-top lid onto the test tube.

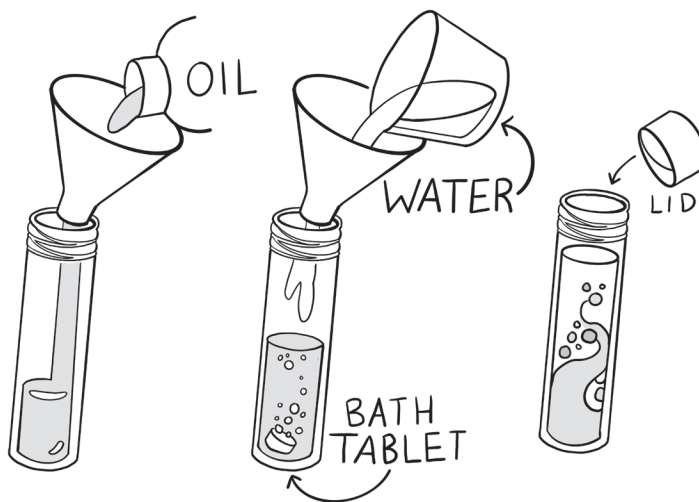

Kids Said ...

“I’ll watch this every day!”
“I like this a lot.”

LIGHT BULB STRING ART

CRAFT CONNECTION

Say: “Just as you’re starting this craft with an empty light bulb outline, the women found an empty tomb in today’s story. However, we know that the empty tomb was not the end of the story. Jesus is the Light of the world and He still shines brightly today. This means that He shows us how to have a relationship with God and how to repent and receive forgiveness from our sins. Every time you see this light bulb, it can remind you that Jesus is alive and is our Savior, now and forever.”

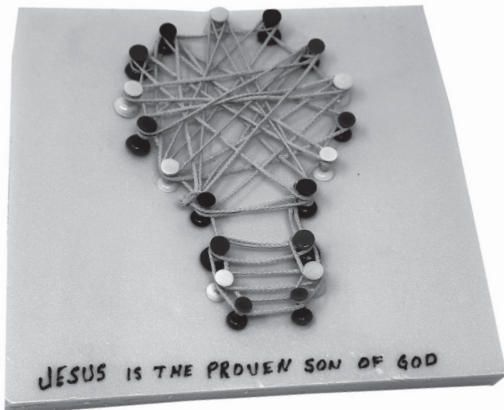

GATHER

- ❑ Templates
 - ❑ “Large Light Bulb Template” (p. 31)
- ❑ ½-inch insulation foam (one 9-by-7-inch piece per kid)
- ❑ Push pins (22 per kid)
- ❑ Yellow string (approximately 36 inches per child)
- ❑ Scissors
- ❑ Permanent markers in several colors

LEADER PREP

- ❑ Print a “Large Light Bulb Template” for each kid.
- ❑ Cut a 3–4-foot length of string for each kid.

LEADER TIPS

- For older kids, consider using two colors of string and having them string the top part of the bulb and the bottom part of the bulb separately to create a more detailed pattern.

NOTES FROM OUR TESTER

- Tie knots for younger kids.
- Older girls wanted more string to make patterns more intricate.

ASSEMBLE

Step 1: Cut out the “Large Light Bulb Template” and use four push pins to secure it to the foam board at the top, bottom, left and right side of the outline.

Step 2: Use a push pin to punch a hole in each dot. Remove the anchor push pins and discard the paper, then place a push pin in each mark you made to fill in the outline. Leave two empty spots near each other.

Step 3: Tie a knot in one end of the string length. Put a pin through the knot and into one of the empty spots.

Step 4: Wind the string up and down and across the shape, wrapping it around each pin at least once as you work to cover the outline.

Step 5: Tie a knot in the other end of the string and place a pin through it to secure it in the other empty spot.

Step 6. Guide kids to write Today’s Point (*Jesus is the proven Son of God.*) on the bottom of their foam board using permanent markers.

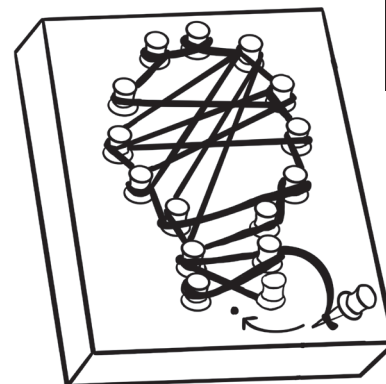
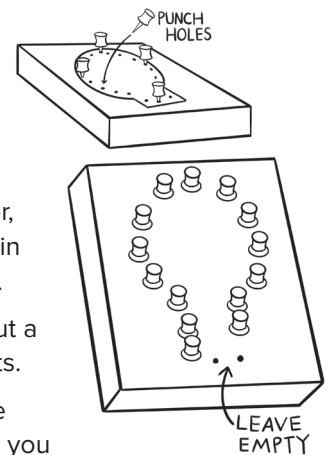

FINISH IN
LAST HOLE

Kids Said ...
“I’ll hang this on my wall.”
“This is cool.”

DAY 5

JESUS IS GOD'S PLAN FOR FORGIVENESS



BIBLE STORY

Peter Preached About Jesus (*Acts 2*)

Spotlight Question: Why do I need to respond to Jesus?

Jesus is the only way to receive God's forgiveness.

Today's Point: Jesus is God's plan for forgiveness.

THEME VERSE

- Jesus spoke to them again: "I am the light of the world. Anyone who follows me will never walk in the darkness but will have the light of life."

John 8:12

- Then spake Jesus again unto them, saying, I am the light of the world: he that followeth me shall not walk in darkness, but shall have the light of life. *John 8:12 (KJV)*

BONUS VERSE

- Repent and be baptized, each of you, in the name of Jesus Christ for the forgiveness of your sins, and you will receive the gift of the Holy Spirit. *Acts 2:38*

- Repent, and be baptized every one of you in the name of Jesus Christ for the remission of sins, and ye shall receive the gift of the Holy Ghost. *Acts 2:38 (KJV)*

BIBLE STORY SUMMARY

Peter Preached About Jesus (*Acts 2*)

Peter and the other disciples stood up in front of a crowd. Peter said God proved who Jesus was by doing miracles, wonders, and signs through Him. God sent His Son, Jesus, to earth to die and take the punishment for our sins. The people were very sorry for their sins. They asked what they should do. Peter told them to repent—turn from disobeying God to obeying God—and be baptized in the name of Jesus for the forgiveness of their sins. That day about 3,000 people responded to Peter's message, repented, and were baptized.

TRACE ART CANDLE

CRAFT CONNECTION

Say: “In our theme verse, Jesus said that He is the Light of the world. He also promised that whoever follows Him will never walk in the darkness. Jesus was using darkness to describe how sin affects our lives. Living your life disobeying God is like walking down a path in the dark without any light. You cannot see where you are going and eventually you will get hurt. Choosing to receive God’s gift of forgiveness and to follow Him with your life is like walking with a strong light. Jesus shows us how to live and helps us obey God. This candle can help you remember what Jesus said about light and darkness. I hope you will choose to follow Jesus and have His light.”

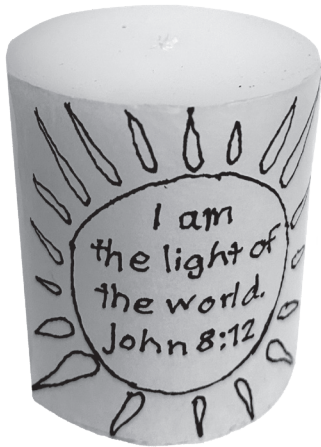

GATHER

- ❑ Templates
 - ❑ “Candle Template” (p. 32)
- ❑ White pillar candle (2.5-by-2.8-inch or similar, 1 per kid)
- ❑ White tissue paper
- ❑ Waxed paper
- ❑ Fine-tipped permanent markers
- ❑ Scissors and clean nail scissors
- ❑ Blow dryer
- ❑ Tape

LEADER PREP

- ❑ Print a “Candle Template” for each kid.
- ❑ Cut 5-by-5-inch pieces of white tissue paper and waxed paper for each kid.
- ❑ Tape a piece of tissue paper over each candle template.
- ❑ Cut the wick off of each candle—this is meant to be decorative and not to be burned! Nail clippers are an effective tool for this.

LEADER TIPS

- Allow kids to create their own design straight on white tissue paper if they want.
- For younger kids, use larger candles and increase the size of your template to make it easier to trace.
- Explain to kids that this candle doesn’t have a wick because it’s not meant to be burnt but to remind them of VBS. Remind kids not to ever use matches without an adult present.

Kids Said ...
“This is cute.”
“I’ll never burn it.”

ASSEMBLE

Step 1: Gently trace the template onto tissue paper. Trim the tissue paper so it will fit on the candle.

Step 2: Place the tissue paper onto the side of the candle and smooth it against the candle’s surface. Overlay it with a sheet of waxed paper. Tape down the edges of the waxed paper.

Step 3: Apply heat to the waxed paper with a blow dryer until the drawing transfers to the candle. Peel away the waxed paper, leaving the tissue paper behind. Check and redo any corners that aren’t stuck down.

LEADER TIP

Older children may be able to use the blow dryer with supervision. Younger children will need an adult to complete step 4 for them.

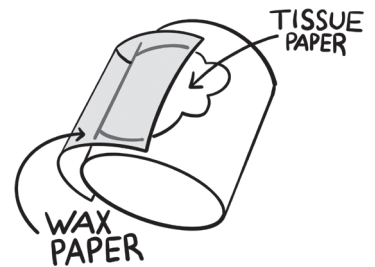
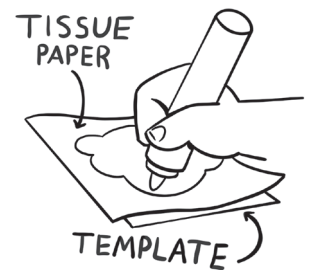

CRAFT PACK

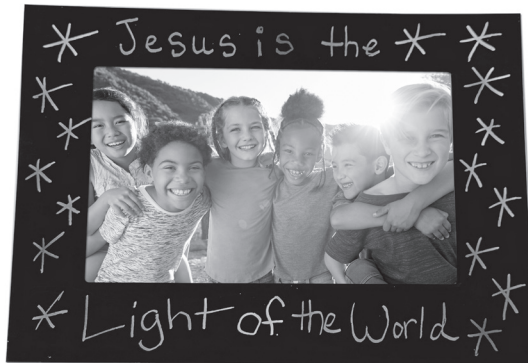

SCRATCH ART FRAME

CRAFT CONNECTION

Say: "It probably didn't make sense to cover up your drawing with black paint. Suddenly your hard work was gone! But once you scratched the motto and your design into the frame, the beautiful colors from beneath could shine through. It probably also didn't make much sense when Peter and the other disciples were speaking different languages to tell people about Jesus. The people were confused. But God had a plan to help many people understand how to respond to Jesus. That's something you and I need to do as well!"

GATHER

- White cardstock
- Unwrapped crayons
- Dish soap
- Black paint
- Small foam bowl
- Foam paintbrush
- Skewers or chopsticks
- Scissors
- Blow dryer
- 1-inch self-adhesive magnet pieces
- Tape
- Craft knife (leader use only)

LEADER PREP

- Consider taking photos of children earlier in the week so they can insert a photo into their scratch art frame.
- Cut out frame shapes from white cardstock to fit your photos using scissors and the craft knife.
- Cut pieces of cardstock to fit inside the frames (optional, if you did not make photos)

ALTERNATE OPTION

Materials for a similar craft can be found in the VBS 2026 Scratch Art Frame Craft Pack (9798384539865).

Kids Said ...

"This is awesome!" "I'll make a picture for Miss Courtney."

ASSEMBLE

Step 1: Use crayons to color the entire frame of cardstock. Random patterns and shapes make for the most interesting finished design. Use the sides of crayons to cover the whole space more quickly.

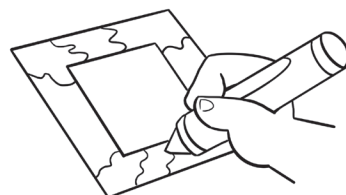

Step 2: Mix equal amounts of dish soap and black paint in a bowl. Cover the entire crayon design with the black paint mixture by dabbing on paint and then smoothing it out gently with a brush.

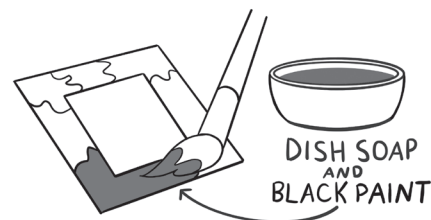

Step 3: Use a blow dryer to help the mixture dry on the paper. While leaders dry the frames, provide cardstock, crayons, and stickers and allow kids to decorate a card to place in their frames if you did not have photos made.

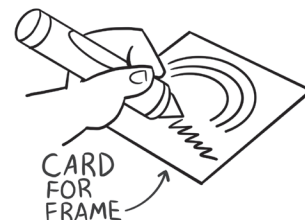

Step 4: Once the cardstock is dry, use a stick to scratch a design. Encourage children to write the motto on their frame. (*Jesus is the Light of the world.*)

Step 5: Add a self-adhesive magnet to the back of the frame. Attach a photo of the child or the card he has made to the frame with tape.

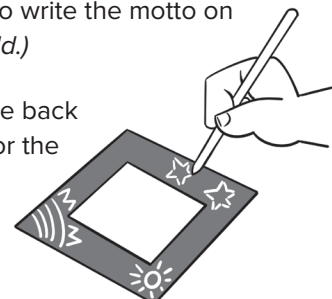

LEADER TIP

Older children may be able to use the blow dryer with supervision. Younger children will need an adult to complete step 3 for them.

DAZZLING KALEIDOSCOPE

CRAFT CONNECTION

Say: "I am so glad you have spent time with me this week in Kaleidoscope Crafts! When you look at the beautiful colors reflected in this kaleidoscope, I hope you'll remember how we spent time at VBS shining a light on who Jesus really is." Take time as kids work to ask them what they've learned about Jesus during VBS.



FAVORITE OF THE DAY

GATHER

- Paper towel tube (1 per kid)
- Rubber bands (3 per kid)
- Tape
- Clear plastic wrap (5-inch square/child)
- Tracing paper (5-inch square/child)
- Black paper (5-inch square/child)
- Long-reach hole punch (leader use only)
- Mirror paper
- Small translucent beads or multi-colored sequins
- Decorative paper
- Decorative tape
- Ruler and scoring tool

LEADER PREP

- Cut tracing paper, plastic wrap, and construction paper into 5-inch squares.
- Use a long-reach hole punch to punch a hole in the center of the black construction paper square.
- Cut mirror paper into 11-by-3¾-inch pieces (1 per kid).
- Score the white side of the mirror paper every 1¼ inches.
- Fold the mirror paper along the scored lines with the mirror side facing in. Tape the edges of the triangle this creates together so that the mirror paper is facing inward.

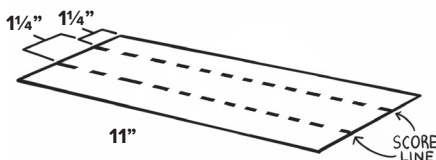

Kids Said ...
 "Dangerously fun."
 "I'll use it outside."

ASSEMBLE

Step 1: Place the clear plastic piece over one end of the cardboard tube. Secure with a rubber band, then tape. Place the tracing paper over the plastic and crease it against the cardboard tube, then remove and set on the table like a cup.

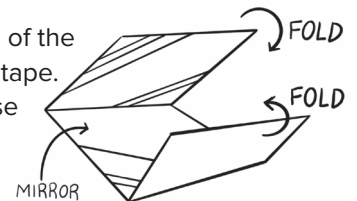

Step 2: Fill the bottom of the tracing paper "cup" you made with beads or sequins. Set the plastic covered end of the cardboard tube in the cup, sandwiching the beads between the plastic and the tracing paper. Secure with a rubber band, then tape for extra security.



Step 3: Insert the mirror paper into the tube.

Step 4: Place the black paper over the opposite end of the tube. Secure with a rubber band, then tape.

Step 5: Wrap the tube with decorative paper. Place decorative tape around each end to finish.

Step 6: Raise the kaleidoscope toward a light source, look into the hole in the black paper, through the mirror paper core, and enjoy the way the colors reflect off the mirror paper.

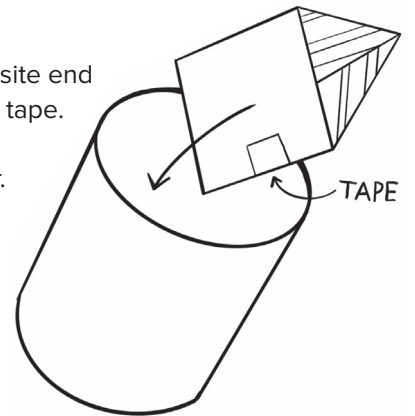

3-5 DAY CRAFT

DIY STAINED-GLASS WINDOW

CRAFT CONNECTION

Say: “Stained-glass art is an intricate design of individual shapes and pieces which come together to create a beautiful image. However, that image is most beautiful when the light shines through it. We also are intricately designed by a Creator who loves us and made us in His image. When we let His light shine through us we are shining a light on who Jesus really is so others can know Him too. He wants a relationship with each of us because He loves us. He is the only way to receive God’s forgiveness.”



Day 1

GATHER

- ❑ Templates
 - ❑ “Stained-glass Art Templates 1-3” (page 32)
- ❑ 8-by-10 picture frame with plastic insert
- ❑ Black permanent markers

ASSEMBLE

Step 1: Carefully remove the backing from the picture frame and remove the plastic insert.

Step 2: Set the plastic insert on one of the stained-glass art templates.

Step 3: Use a permanent marker to trace the template onto the plastic insert.

Tip: Be careful not to smudge the lines while drawing.

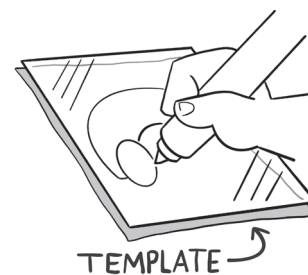
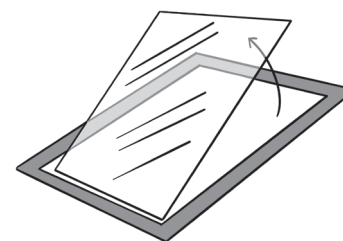

Day 2

GATHER

- ❑ Squeeze bottles
- ❑ Black acrylic paint
- ❑ Glue
- ❑ Foam bowls
- ❑ Spoon
- ❑ Funnel
 - ❑ Mix black acrylic paint with glue in a bowl until you achieve a dark color.
 - ❑ Pour the mixture into squeeze bottles using a funnel.

ASSEMBLE

Step 1: Use the squeeze bottle to trace the template lines drawn onto the plastic insert.

Step 2: Ensure there are no gaps in the lines.

Step 3: Allow the glue/paint mixture to dry overnight.

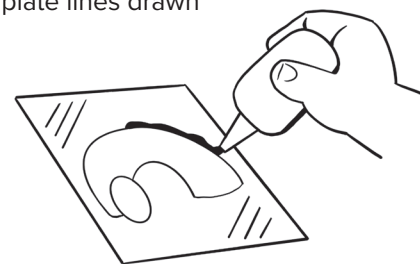

Day 3

GATHER

- Watercolors
- Paintbrushes
- Paint cups
- Cool melt hot glue gun (adult use only)

ASSEMBLE

Step 1: Use watercolors to paint the shapes on the plastic insert.

Step 2: Allow paint to dry.

Step 3: Once the paint is dry, place the plastic insert back into the picture frame, but do not replace the backing.

Step 4: Use a hot glue gun to secure the plastic insert in the frame.

PRETEEN CRAFTS

Note: Full step-by-step instructions for each craft can be found in the *VBS 2026 VBX® Preteen Bible Study Leader Guide* (9798384536949) on pages 15, 22, 29, 36, and 43.

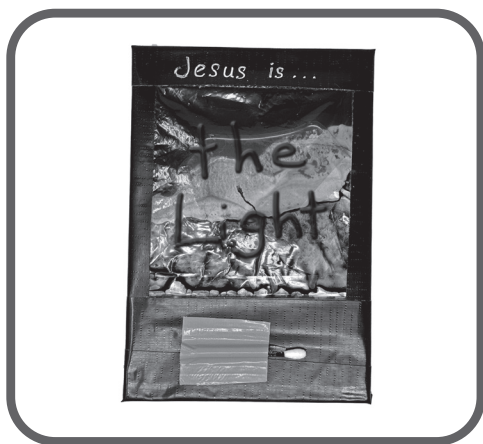

Day 1 Jesus Is ... Tablet

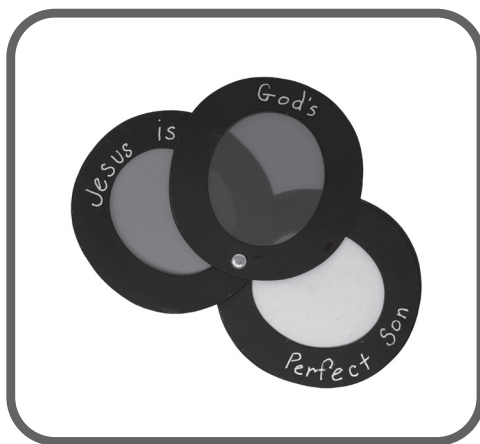

Day 2 Color Wheel

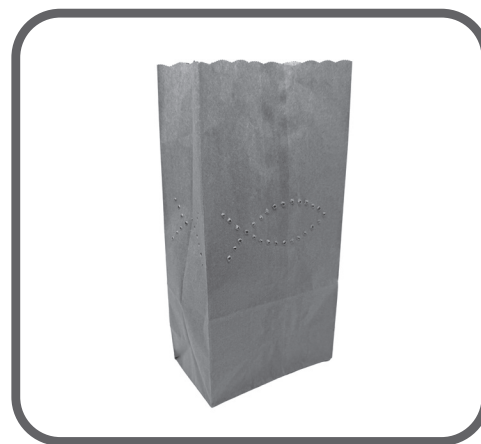

Day 3 Lunch Sack Luminaries



Day 4 Glow-in-the-dark Zipper Pull

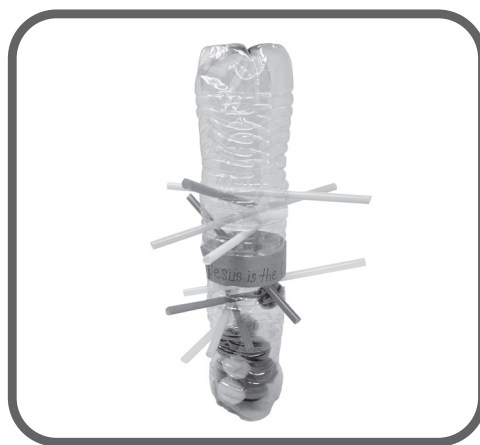

Day 5 Noiseless Neon Tumble Game

TEMPLATES

All templates can also be found, full-size and available to download, using the code on page 2. Unless otherwise marked, make sure to print at "Actual Size" or 100% to get the intended size.

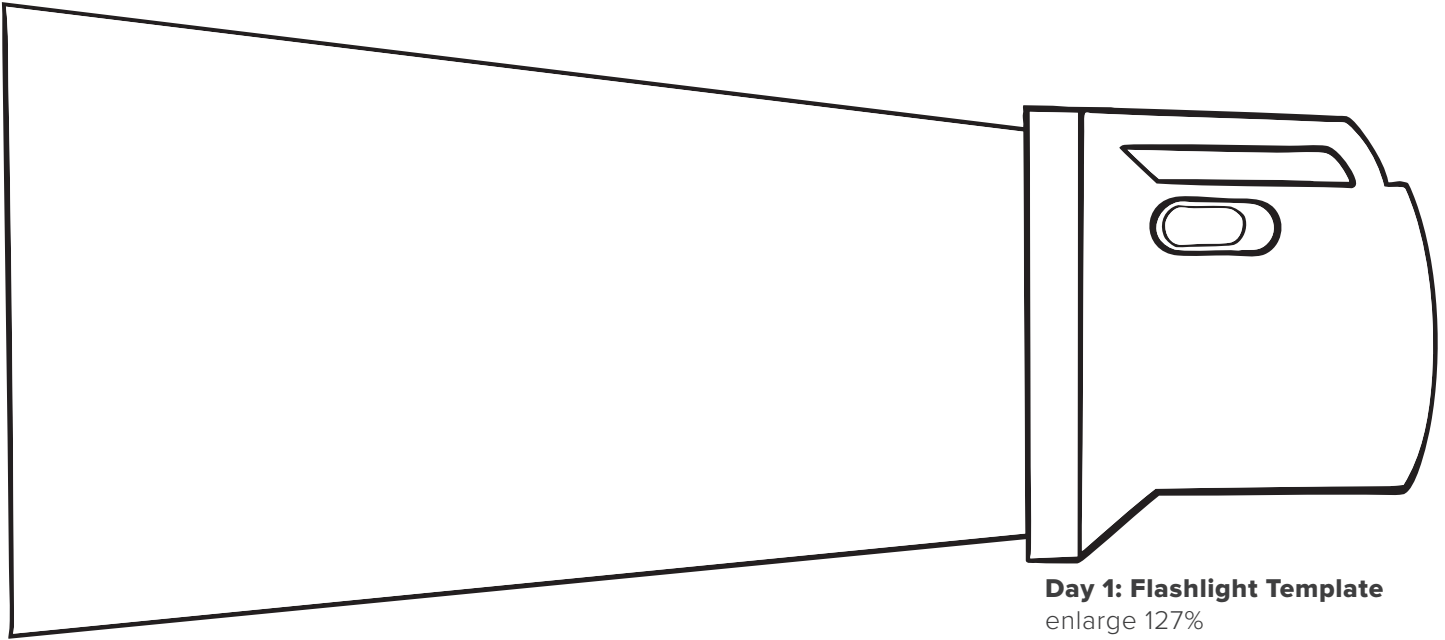

Day 1: Flashlight Template
enlarge 127%



Day 1: Names of Jesus Template
enlarge 155%

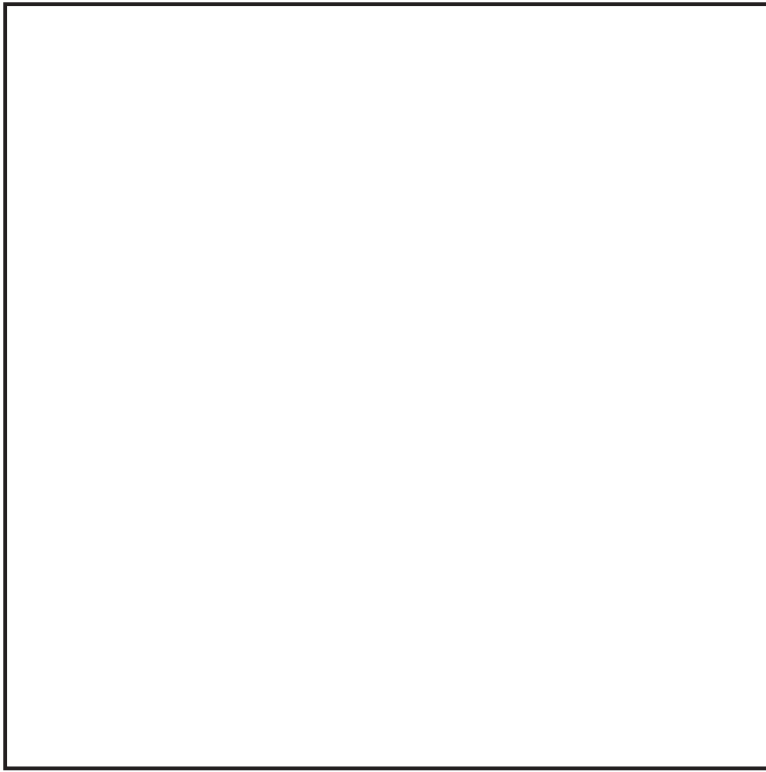

Day 1: Square Template
enlarge 138%

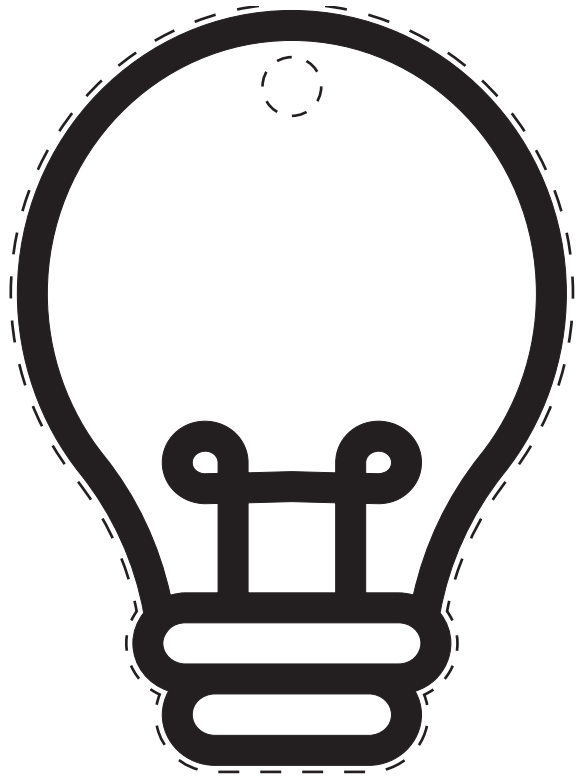

Day 3: Small Light Bulb Template



Day 2: Baptism Scene Template
enlarge 129%

Day 3: Fish Template
enlarge 143%

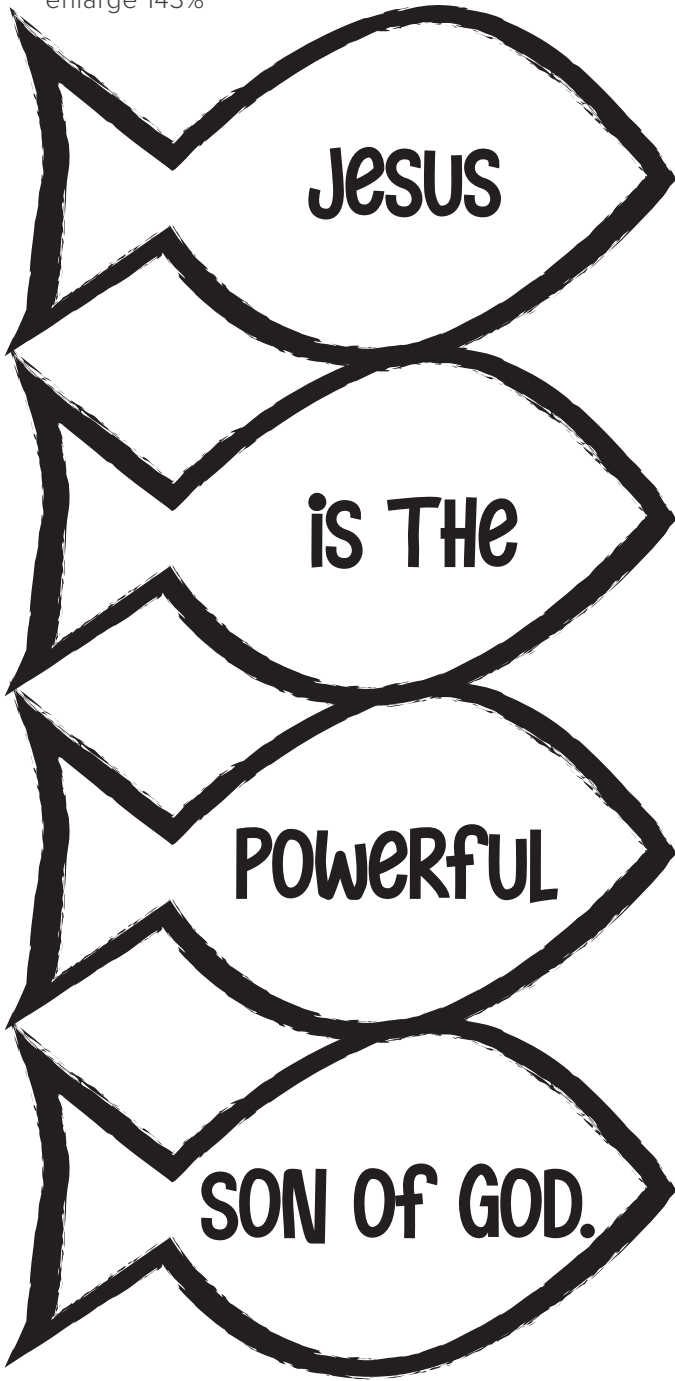

Day 4: Empty Tomb Template

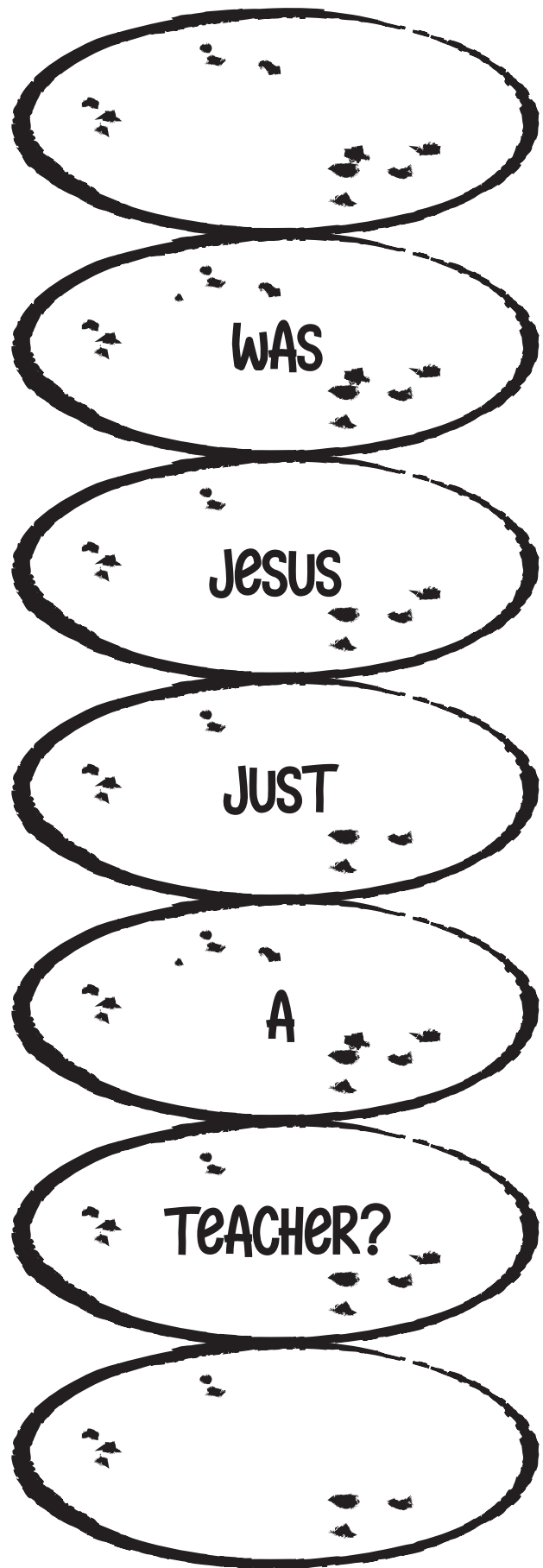

Day 3: Loaves Template
enlarge 185%

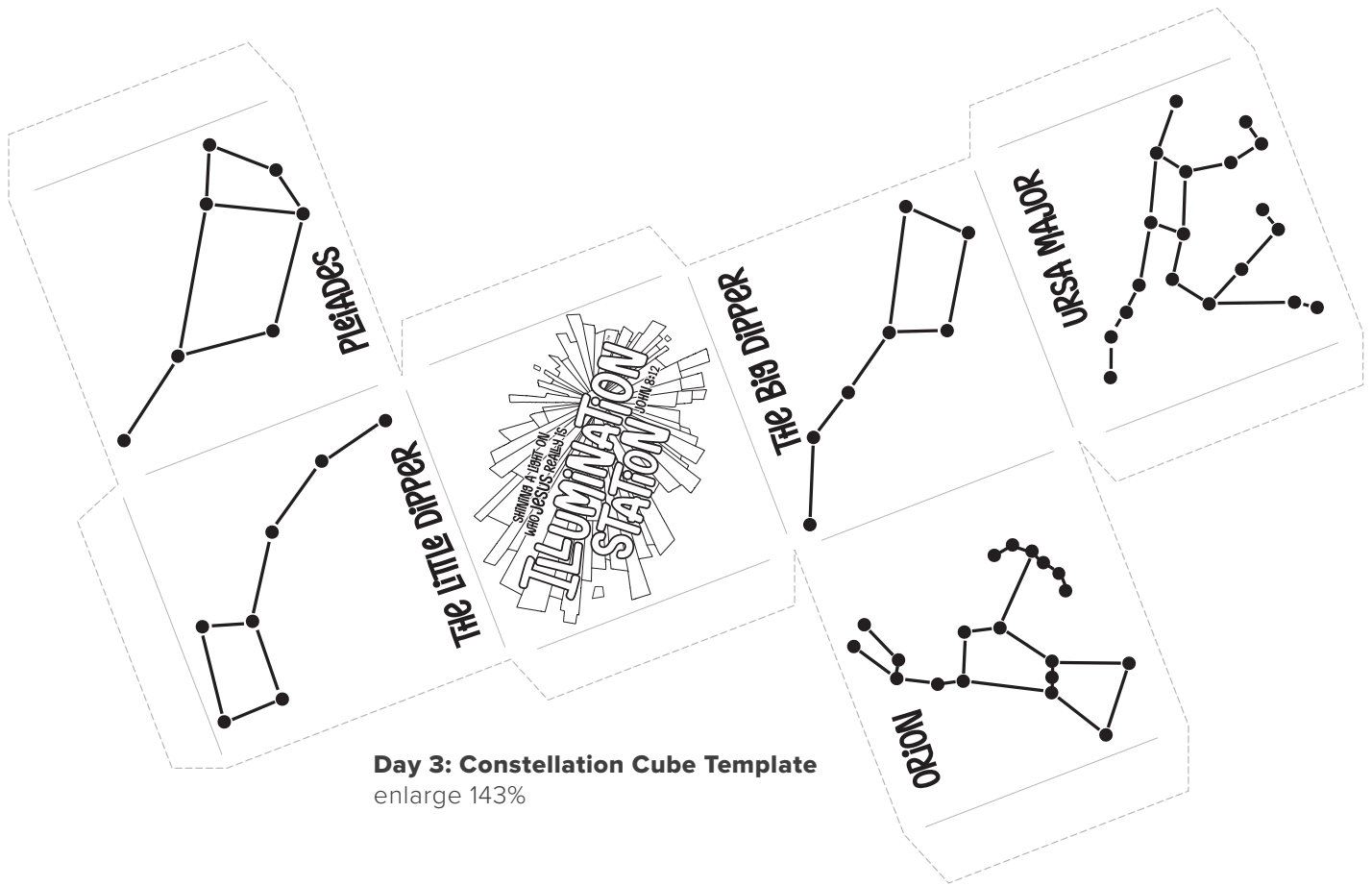

Day 3: Constellation Cube Template
enlarge 143%

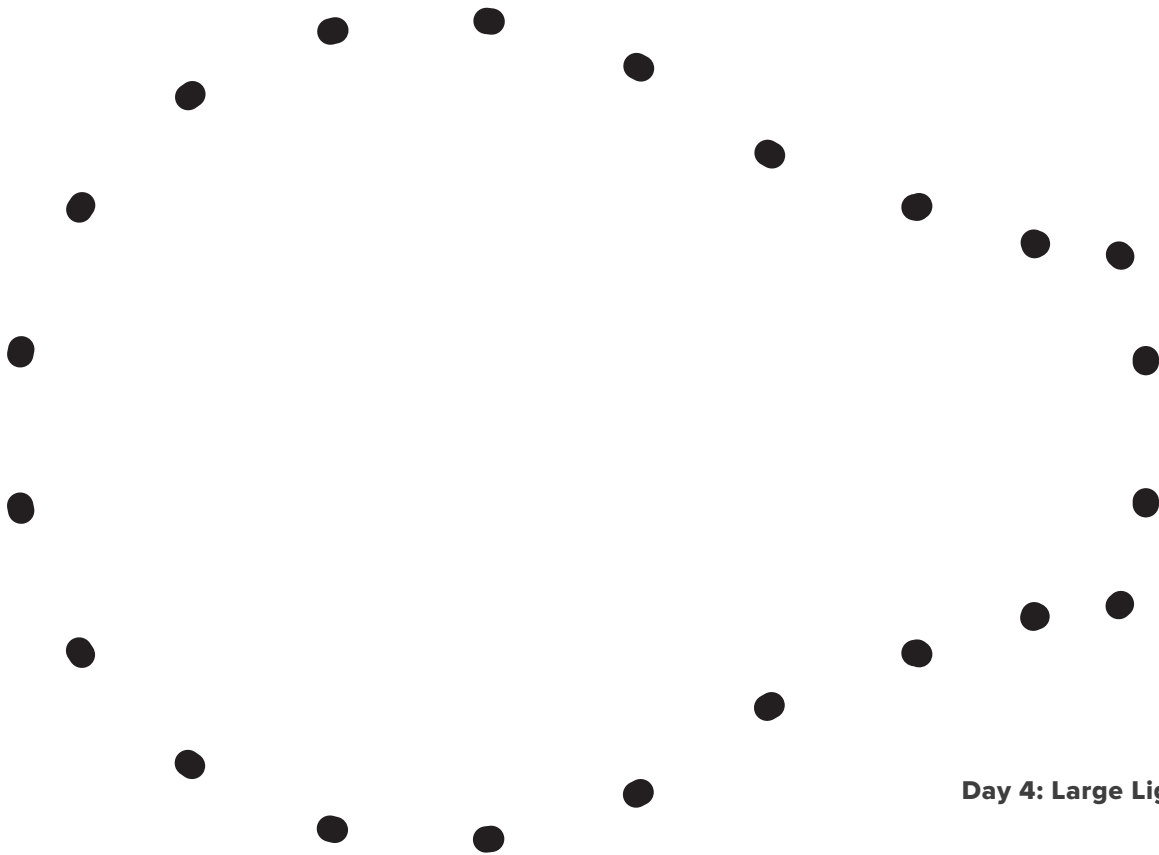

Day 4: Large Light Bulb Template

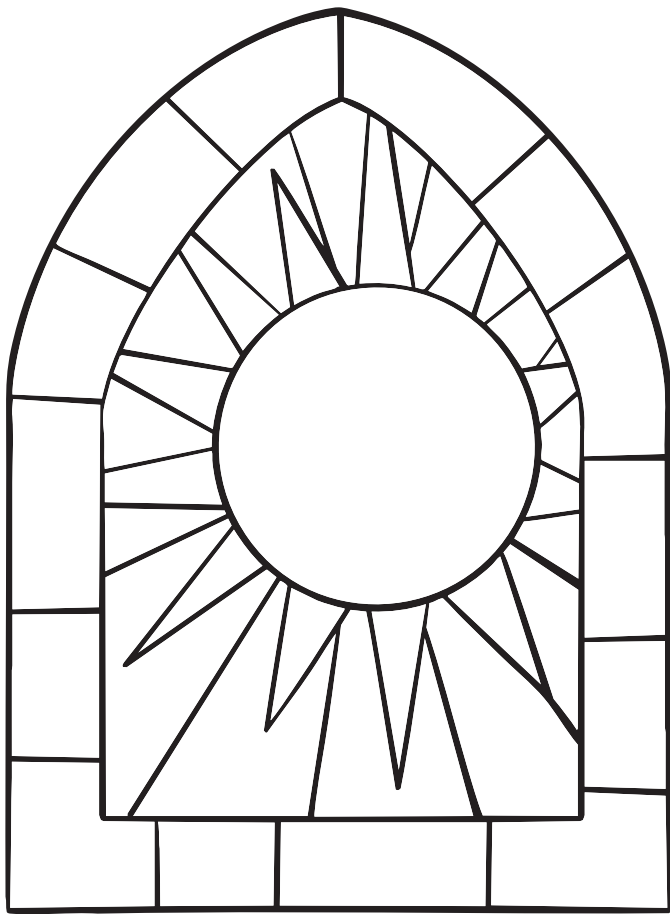

3-5 Day: Stained-glass Art Template 1
enlarge 186%

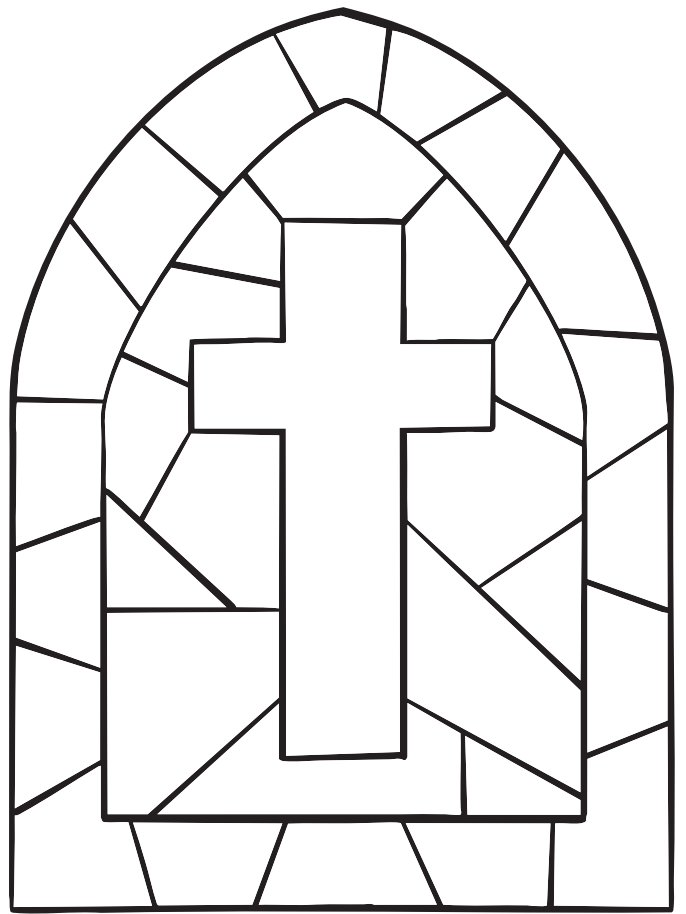

3-5 Day: Stained-glass Art Template 2
enlarge 186%



Day 5: Candle Template

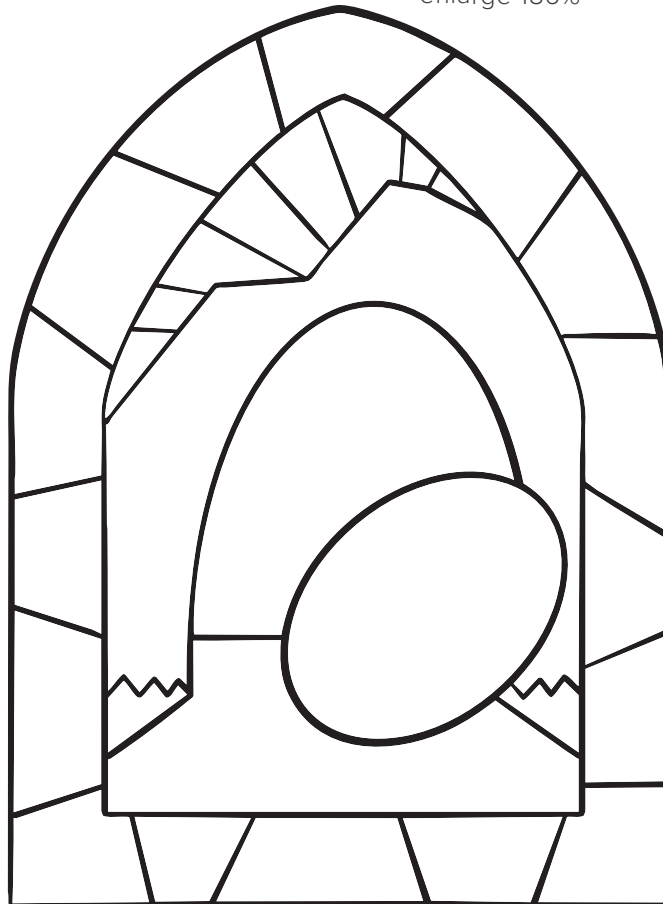

3-5 Day: Stained-glass Art Template 3
enlarge 186%

ILLUMINATION STATION JOHN 8:12

SAVE TIME AND MONEY WITH VBS CRAFT PACKS!

Many of the great craft ideas in the 2026 Craft Rotation Leader Guide are available in easy-to-use craft packs. Each craft pack contains supplies for ten kids and instructions that help point to the day's Bible lesson.



VBS 2026 CRAFT STICK LANTERN CRAFT PACK
005853778 • 9798384539841 • \$6.75



VBS 2026 CONSTELLATION CUBE CRAFT PACK
005853787 • 9798384539872 • \$6.75



VBS 2026 BAPTISM STICKER SCENE CRAFT PACK
005853776 • 9798384539834 • \$6.75



VBS 2026 EMPTY TOMB SILHOUETTE CRAFT PACK
005853788 • 9798384539889 • \$6.75



VBS 2026 ILLUMINATION STATION SHRINK PLASTIC CRAFT PACK
005853779 • 9798384539858 • \$6.75



VBS 2026 SCRATCH ART FRAME CRAFT PACK
005853780 • 9798384539865 • \$6.75



SCAN TO ORDER YOUR CRAFT
RESOURCES TODAY AT Lifeway.com

Prices and availability subject to change.

Lifeway VBS

JESUS IS THE LIGHT OF THE WORLD

Culture claims to know about Jesus, but many people are in the dark about who He really is. Some might see Jesus as just a person from history or a good man or a good teacher—but He is more than that! Illumination Station VBS will shine a light on the truth of who Jesus really is. Like the disciples, kids will be challenged to answer Jesus' question, "Who do you say that I am?" They will discover it's not a matter of opinion. Jesus is who Scripture says He is—the perfect, proven, and powerful Son of God.

Lifeway VBS

lifeway.com/vbs